

# HOFMANN



## INSTALLATION and OPERATION MANUAL



### 14K SCISSOR LIFT

BLA14178, BLA14178FM, BLA14178LL

**READ THIS INSTRUCTION MANUAL THOROUGHLY  
BEFORE INSTALLING, OPERATING, SERVICING OR  
MAINTAINING THE LIFT. SAVE THIS MANUAL.**



309 Exchange Avenue • Conway, AR 72032  
(800) 251-4500 • (501) 505-2662  
Fax (501) 450-2085 • [www.hofmann-usa.com](http://www.hofmann-usa.com)



6500 Millcreek Drive • Mississauga, ONT L5N 2W6  
(800) 267-2185  
Fax (905) 821-2073 • [www.hofmann.ca](http://www.hofmann.ca)

NOV 2010 REV. A 6-3014

## TABLE OF CONTENTS

<b>1.0 SAFETY INSTRUCTIONS.....</b>	<b>4</b>
<b>2.0 SAFETY WARNING DECALS .....</b>	<b>6</b>
<b>3.0 SPECIFICATIONS .....</b>	<b>7</b>
<b>4.0 CONTENTS.....</b>	<b>8</b>
<b>5.0 TOOLS REQUIRED FOR INSTALLATION OF LIFT .....</b>	<b>8</b>
<b>6.0 INSTALLATION OVERVIEW .....</b>	<b>9</b>
<b>7.0 INSTRUCTIONS.....</b>	<b>10</b>
7.1 Flushmount Bay Layout.....	11
7.2 Surfacemount Bay Layout .....	12
7.3 Baseframe Location .....	13
7.4 Unpacking the Lift .....	14
7.5 Hydraulic Connections .....	15
7.6 Air Safety and Auxiliary Air connections .....	17
7.7 Pneumatic Sensor Connections.....	19
7.8 Electrical Connections.....	21
7.9 Initial Operation .....	22
7.10 Equalizing Function Check.....	23
7.11 Maximum Height Adjustment .....	24
7.12 Level and Support .....	25
7.13 Anchoring Procedure.....	26
7.14 Grouting Procedure (Optional).....	27
<b>8.0 ACCESSORY INSTALLATION.....</b>	<b>28</b>
8.1 Installation of Line Covers.....	30
<b>9.0 LOCKING FRONT TURNPLATES &amp; REAR SLIP PLATES (OPTIONAL) ..</b>	<b>31</b>
9.1 Installation of Front Turnplates.....	31
9.2 Console Connections for Locking & Lights .....	33
<b>10.0 FINAL PROCEDURES.....</b>	<b>35</b>
10.1 Check of Assembled Lift.....	35
10.2 Operation Test with Vehicle.....	35
<b>11.0 LIFT OPERATION.....</b>	<b>36</b>
11.1 Raising the Lift.....	36
11.2 Lowering the Lift.....	36
<b>12.0 RECOMMENDED MAINTENANCE .....</b>	<b>37</b>
12.1 Checking Oil Level for Air Lubricator .....	37
12.2 Maintenance of Turnplate & Slip Plate Locking System (Opt.).....	38
<b>13.0 TROUBLE SHOOTING .....</b>	<b>40</b>
<b>14.0 RECORD OF MAINTENANCE / TRAINING .....</b>	<b>41</b>

<b>15.0 LIFT ASSEMBLY .....</b>	<b>42</b>
<b>15.1 Lift Assembly Parts List.....</b>	<b>43</b>
<b>16.0 HYDRAULIC &amp; AIR ASSEMBLY .....</b>	<b>45</b>
<b>16.1 Line Routing Parts List .....</b>	<b>47</b>
<b>17.0 HEIGHT LIMIT ASSEMBLY.....</b>	<b>48</b>
<b>17.1 HEIGHT LIMIT / LEVELING PARTS LIST .....</b>	<b>48</b>
<b>17.2 EQUALIZE SENSORS PARTS LIST .....</b>	<b>49</b>
<b>17.3 HEIGHT LIMIT / LEVELING PARTS LIST .....</b>	<b>49</b>
<b>17.4 OPTIONAL: LIGHT KIT SENSOR PARTS LIST .....</b>	<b>50</b>
<b>18.0 ACCESSORY ASSEMBLY .....</b>	<b>51</b>
<b>18.1 Front Turnplate .....</b>	<b>51</b>
<b>18.2 Rear Slip Plate Locking Mechanism .....</b>	<b>53</b>
<b>18.3 Airline Routing for Locking Turnplates and Rear Slip Plates.....</b>	<b>54</b>
<b>18.4 Rear LED Light Assembly: Exploded View .....</b>	<b>56</b>
<b>19.0 CONSOLE ASSEMBLY .....</b>	<b>58</b>
<b>19.1 Electrical Panel.....</b>	<b>58</b>
<b>19.2 Console: Pneumatic &amp; Filtering System.....</b>	<b>59</b>
<b>19.3 Console: Pneumatic &amp; Filtering System -         Locking &amp; Light System (Optional).....</b>	<b>60</b>
<b>19.4 PNEUMATIC LIMIT SWITCH SCHEMATIC.....</b>	<b>61</b>
<b>19.5 Control Panel .....</b>	<b>63</b>
<b>19.6 Console Panel Assembly .....</b>	<b>64</b>
<b>20.0 POWERPACK ASSEMBLY .....</b>	<b>65</b>
<b>20.1 Powerpack Assembly.....</b>	<b>65</b>
<b>20.2 Manifold Parts List .....</b>	<b>67</b>

## 1.0 SAFETY INSTRUCTIONS

When using this lift, basic safety precautions should always be followed, including the following:



1. Read all instructions in this manual and on the lift thoroughly before installing, operating, servicing or maintaining the lift.
2. Inspect the lift DAILY. Do not operate if it malfunctions or problems have been encountered.
3. Never attempt to overload the lift. The manufacturer's rated capacity is shown on the identification label on side of the deck. Do not override the operating controls or safety devices.
4. Only trained and authorized personnel should operate the lift. Do not allow customers or bystanders to operate the lift or be in the lift area.



5. **CAUTION! Never work under the lift unless mechanical safety locks are engaged.**
6. Always keep the lift area free of obstruction and debris. Grease and oil spills should always be cleaned up immediately.
7. Never raise a vehicle with passengers inside.
8. Always chock vehicle wheels before raising or lowering the lift.
9. Before lowering check the area for any obstructions including people.
10. To protect against risk of fire, do not operate the lift in the vicinity of open containers of flammable liquids.
11. Adequate ventilation should be provided when working on internal combustion engines.
12. Never open hydraulic lines under pressure.
13. Do not raise or lower the lift with the vehicle on the Jack Beam.

**READ AND SAVE THESE INSTRUCTIONS**

Installation shall be performed in accordance with ANSO/ALI ALIS, Safety Requirements for Installation and Service of Automotive Lifts.

For additional safety instructions regarding lifting, lift types, warning labels, preparing to lift, vehicle spotting, vehicle lifting, maintaining load stability, emergency procedures, vehicle lowering, lift limitations, lift maintenance, good shop practices, installation, operator training and owner/employer responsibilities, please refer to "Lifting It Right" (ALI/SM) and "Safety Tips" (ALI/ST).

For additional instruction on general requirements for lift operation, please refer to "Automotive Lift-Safety Requirements For Operation, Inspection and Maintenance" (ANSI/ALI ALOIM).



**ATTENTION!** This lift is intended for indoor installation only. It is prohibited to install this product outdoors. Operating environment temperature range should be 41 – 104 °F (5 – 40 °C). Failure to adhere will result in decertification, loss of warranty, and possible damage to the equipment.

+ 070126-Quadra-WLSIA01

## SAFETY INSTRUCTIONS

If attachments, accessories or configuration modifying components that are located in the load path, affect operation of the lift, affect the lift electrical listing or affect intended vehicle accommodation are used on this lift and, if they are not certified for use on this lift, then the certification of this lift shall become null and void. Contact the participant for information pertaining to certified attachments, accessories or configuration modifying components.

[www.autolift.org](http://www.autolift.org)

©2007 by ALI, Inc.

ALI / WLSIA01

## 2.0 SAFETY WARNING DECALS

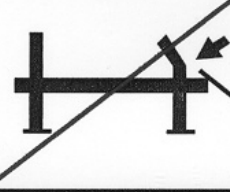
<p><b>⚠ WARNING</b></p>  <p>Clear area if vehicle is in danger of falling.</p> <p>©</p>	<p><b>⚠ WARNING</b></p>  <p>Remain clear of lift when raising or lowering vehicle.</p> <p>©</p>	<p><b>SAFETY INSTRUCTIONS</b></p>  <p>Read operating and safety manuals before using lift.</p> <p>©</p>	<p><b>SAFETY INSTRUCTIONS</b></p>  <p>Proper maintenance and inspection is necessary for safe operation.</p> <p>©</p>
<p><b>⚠ WARNING</b></p>  <p>Keep clear of pinch points when lift is moving.</p> <p>©</p>	<p><b>⚠ WARNING</b></p>  <p>Keep feet clear of lift while lowering.</p> <p>©</p>	<p><b>SAFETY INSTRUCTIONS</b></p>  <p>Do not operate a damaged lift.</p> <p>©</p>	<p>The messages and pictographs shown are generic in nature and are meant to generally represent hazards common to all automotive lifts regardless of specific style.</p> <p>Funding for the development and validation of these labels was provided by the Automotive Lift Institute, PO Box 33116 Indialantic, FL 32903.</p> <p>They are protected by copyright. Set of labels may be obtained from ALI or its member companies.</p> <p>© 1992 by ALI, Inc. ALI/WL200s</p>
<p><b>⚠ WARNING</b></p>  <p>Do not override self-closing lift controls.</p> <p>©</p>	<p><b>⚠ WARNING</b></p>  <p>Chock wheel to prevent vehicle movement.</p> <p>©</p>	<p><b>⚠ CAUTION</b></p>  <p>Lift to be used by trained operator ONLY.</p> <p>©</p>	<p><b>⚠ CAUTION</b></p>  <p>Authorized personnel only in lift area.</p> <p>©</p>
<p>The messages and pictographs shown are generic in nature and are meant to generally represent hazards common to all automotive lifts regardless of specific style</p> <p>Funding for the development and validation of these labels was provided by the Automotive Lift Institute, PO Box 33116 Indialantic, FL 32903</p> <p>They are protected by copyright Set of labels may be obtained from ALI or its member companies</p> <p>© 1992 by ALI, Inc. ALI/WL200w</p>		<p>The messages and pictographs shown are generic in nature and are meant to generally represent hazards common to all automotive lifts regardless of specific style</p> <p>Funding for the development and validation of these labels was provided by the Automotive Lift Institute, PO Box 33116 Indialantic, FL 32903</p> <p>They are protected by copyright Set of labels may be obtained from ALI or its member companies</p> <p>© 1992 by ALI, Inc. ALI/WL200c</p>	

### 3.0 SPECIFICATIONS

Maximum Capacity:	14 000 lbs	6363 kg
Overall Width (min-max):	92½" – 94½" Inches	2350-2400 mm
Overall Length:	270 Inches	6858 mm
Maximum Raised Height:	72 Inches	1829 mm
Minimum Lowered Height:	10 Inches	254 mm
Runway Width	26 Inches	660 mm
Maximum Wheelbase:	176 Inches	4470 mm
Lifting Time (approx.):	65 seconds at max. capacity	
Power Ratings:	230V, 1 Ph, 60Hz, 20A	
Air Supply requirements:	90 to 120 PSI	
Pneumatic Filtration Oil Type:	Snap-On #IM6 or Equivalent	
Hydraulic Oil Capacity:	Tank size: 4.0 gal	Lift capacity: 6.0 gal
Hydraulic Oil Type:	ISO 32 (10 weight) hydraulic oil	
Shipping Weight:	4870 lbs	2209 kg

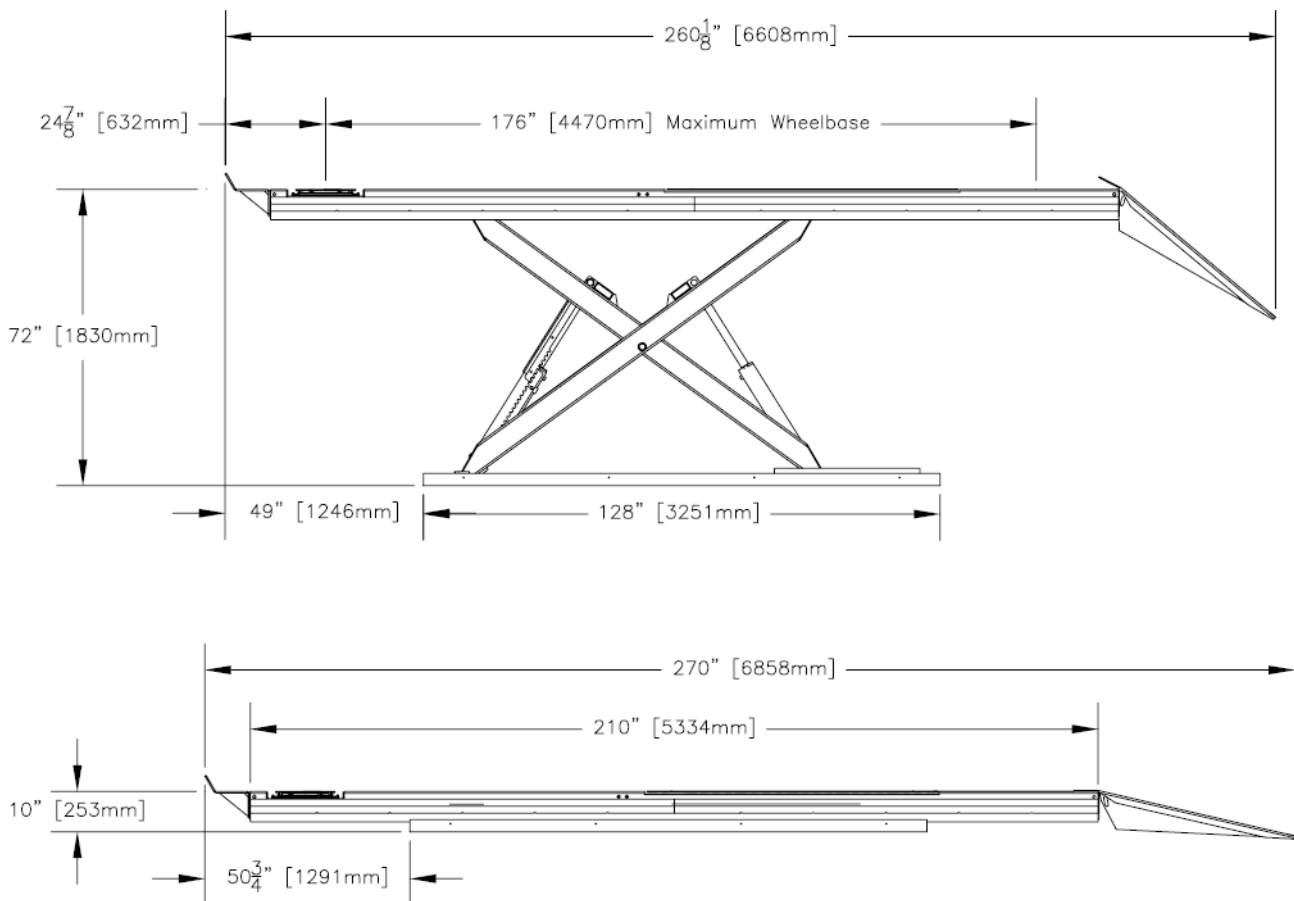

Figure 1 - Lift Dimensions

## 4.0 CONTENTS

The complete lift is contained in two (2) packages:

1. The main structural components are pre-assembled and packaged on top of each other.
2. The remaining parts are packed in a console/accessory box. Refer to the packing slip inside the accessory box for a list contents.

### Components include:

- 1pc. – Left Side Main Frame Assembly: Runway, Scissors and Base Frame
- 1pc. – Right Side Main Frame Assembly: Runway, Scissors and Base Frame
- 1pc. – Console and Accessory box. (See accessory box list for contents)
- 1pc. – Grout container
- 1pc. – Customer care kit including manuals

## 5.0 TOOLS REQUIRED FOR INSTALLATION OF LIFT

- Hammer Drill or similar, 1/4" and 1/2" Concrete Drill Bits
- 4' Level
- SAE Wrenches and Sockets
- Hammer
- Pry Bar – 5' Long
- Chalk Line
- Tape Measure
- Side Cutters
- Screw Drivers
- Funnel
- Utility Knife
- Torque Wrench

### Recommended:

- Laser Leveler
- Plumb Bob
- Impact Gun
- Boom and/or Engine Hoist
- 8' Sling
- Engine Crane

Note: Apply LOCTITE #242 on required fasteners where symbol is shown.  
If fasteners are removed reapply LOCTITE before re-installing.





## 6.0 INSTALLATION OVERVIEW

This is the order in which this installation is to take place:

1. Layout the Bay
2. Unpacking the Lift
3. Inspect the Lift
4. Connect Hydraulic Lines
5. Connect Air Lines
6. Connect Pneumatic Sensors
7. Connect Electrical
8. Initial Run of Lift
9. Level, Shim and Anchor
10. Install Accessories
11. Locking Front Turnplates and Rear Slip Plates / Light System (Optional)
12. Final Check
13. Clean
14. Train Customer on Operation of the Lift

**IMPORTANT: Shop air must be connected to the inlet port at the FRL unit in the console, in order for lift to operate.**

## 7.0 INSTRUCTIONS

When the lift arrives on site please read the owner's installation and operation manual completely. Check the contents to make sure no parts are missing before starting installation. Gather all of the tools listed and make sure that the instructions are fully understood before commencing with the installation.

---



**IMPORTANT:** It is the user's responsibility to provide a satisfactory installation area for the lift. Lifts should only be installed on a level concrete floor with a minimum thickness of four and a quarter (4¼) inches or 108 mm. Concrete must have a minimum strength of 3000 psi or 21 MPa and should be aged thirty (30) days prior to installation. Please consult the architect, contractor or engineer if doubt exists as to the strength and feasibility of the floor to enable proper lift installation and operation.

---



**IMPORTANT:** It is the user's responsibility to provide all wiring for electrical hook-up prior to installation and to ensure that the electrical installation conforms to local building codes. Where required, it is the user's responsibility to provide an electrical isolation switch located in close proximity to the lift that will enable emergency stop capability and isolate electrical power from the lift for any servicing requirements.

---

## 7.1 Flushmount Bay Layout

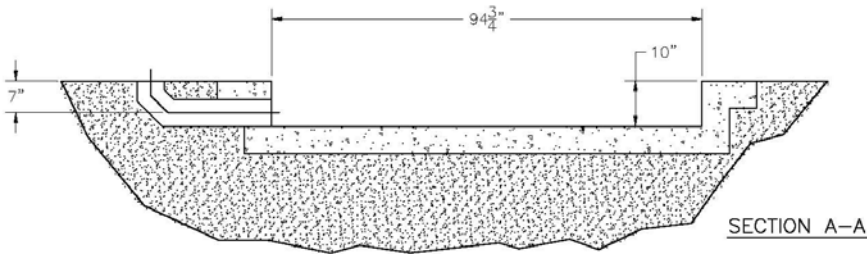

**NOTE:** Leave any additional room for any desired aisle or work area. Recommended clearance around the lift is a minimum of three (3) feet. Ensure clearance conforms to local building and fire codes.

Recommended overhead clearance is a minimum of twelve (12) foot ceiling providing 6 feet for the maximum lift height and 6 feet for the supported vehicle. For vehicles taller than 6 feet it is recommended that the user provides additional overhead clearance or a shut off mechanism to stop the lift from raising the vehicle too high.

**Please contact customer service for latest installation diagram as it may change without notice.**

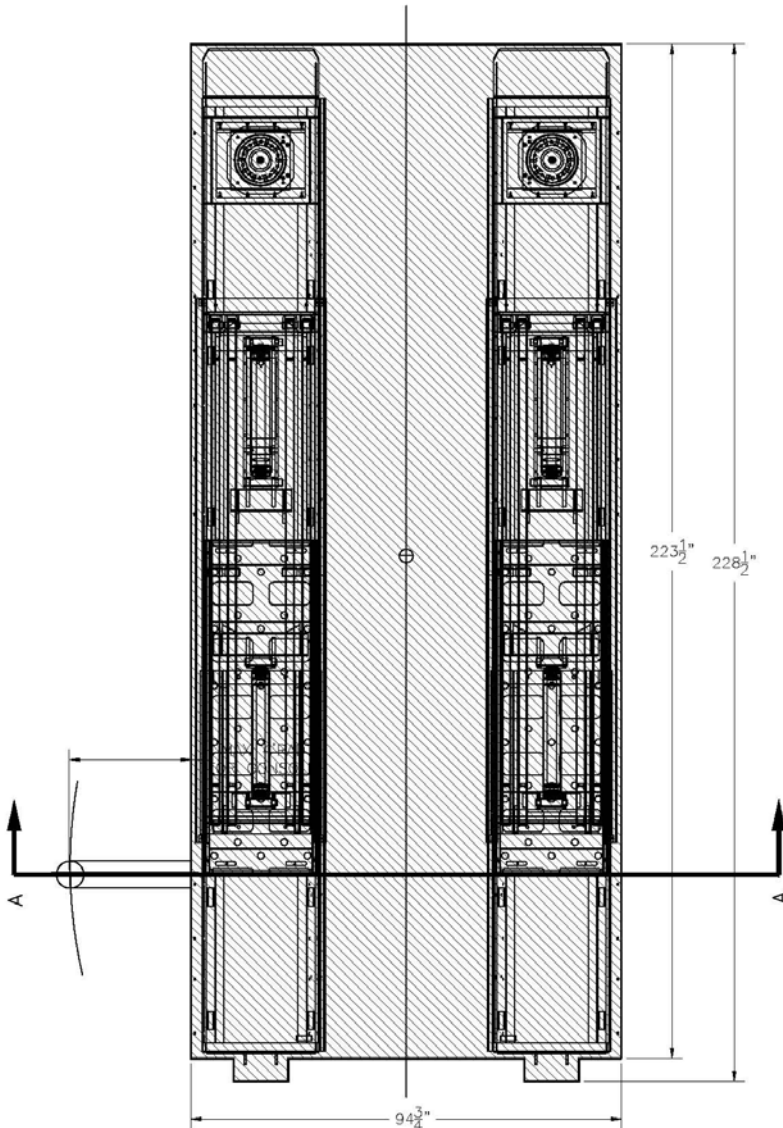

**Figure 2 - Typical Bay Layout (Flush Mount)**

## 7.2 Surfacemount Bay Layout

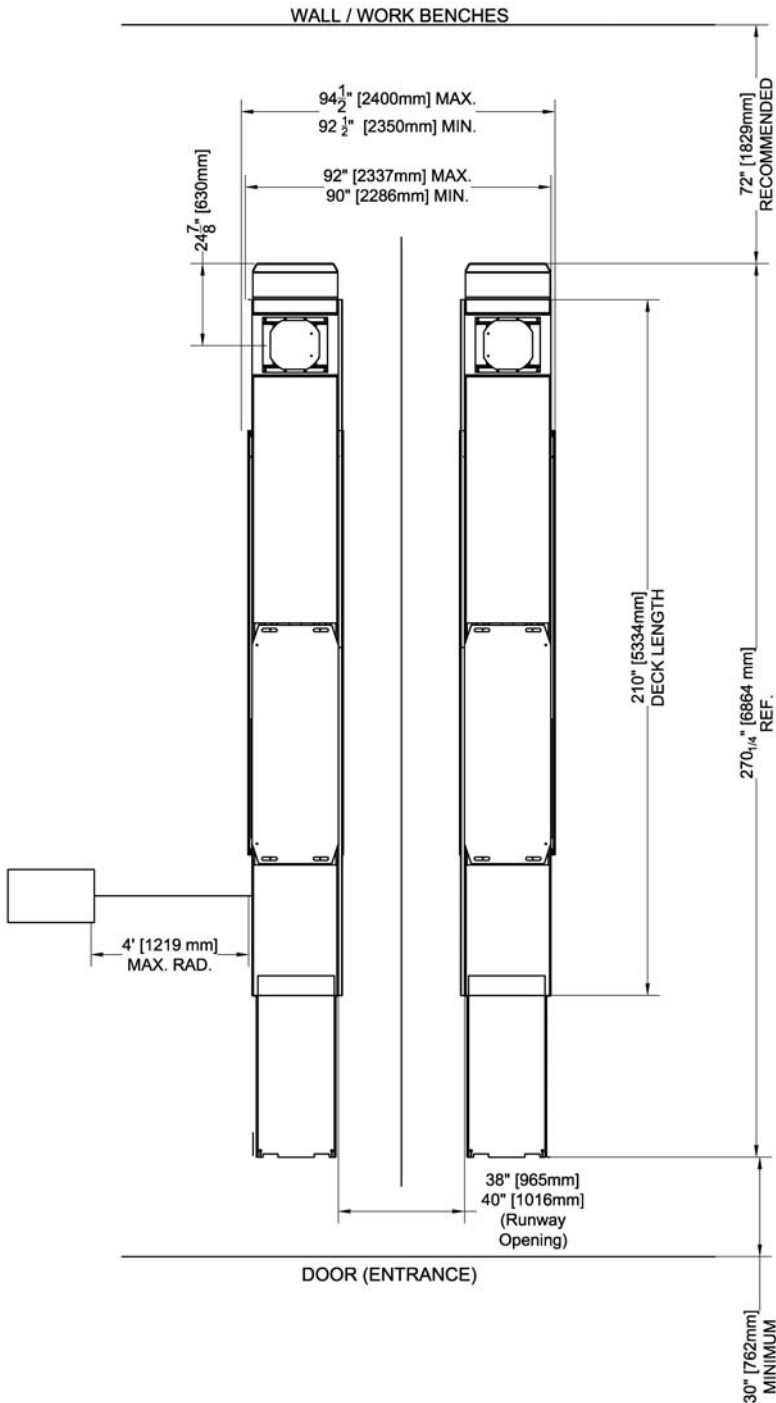

**NOTE:** Leave any additional room for any desired aisle or work area. Recommended clearance around the lift is a minimum of three (3) feet. Ensure clearance conforms to local building and fire codes.

Recommended overhead clearance is a minimum of twelve (12) foot ceiling providing 6 feet for the maximum lift height and 6 feet for the supported vehicle. For vehicles taller than 6 feet it is recommended that the user provides additional overhead clearance or a shut off mechanism to stop the lift from raising the vehicle too high.

**Please contact customer service for latest installation diagram as it may change without notice.**

**Figure 3 - Typical Bay Layout (Surface Mount)**

### 7.3 Baseframe Location

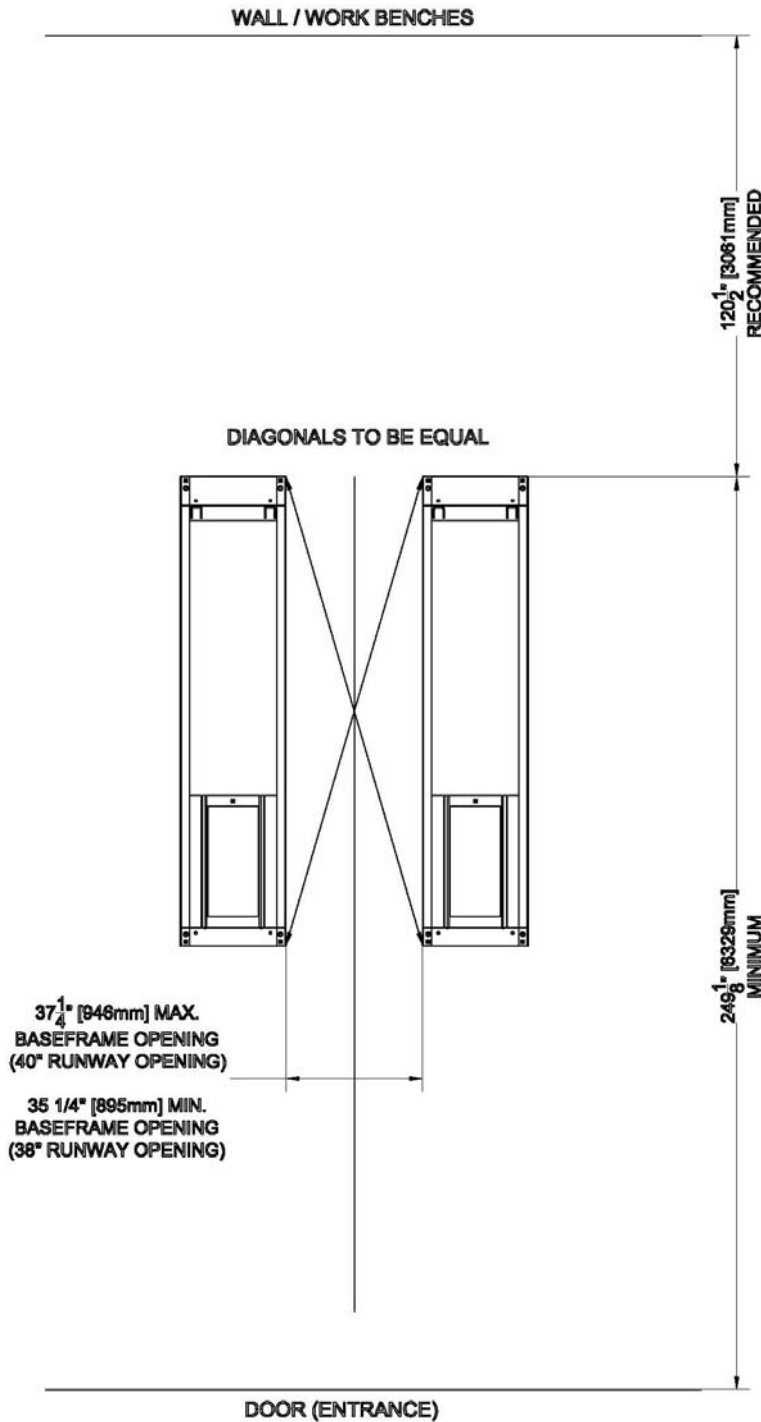

**IMPORTANT: DO NOT CUT THE SHIPPING STRAPS HOLDING EACH SCISSOR ASSEMBLY TOGETHER UNTIL INSTRUCTED TO DO SO.**

1. With reference to **Figure 3**, the installer should locate the most suitable location in the shop for the lift.
2. Snap a chalk line for the centerline of the lift ensuring that it matches the centerline of the bay door.
3. Measure and snap two (2) parallel chalk lines on either side the centerline for the inside edges of the baseframes. Refer to Error! Reference source not found. for the dimensions necessary to provide the desired width between the two runways. A distance of 35 1/4" (895mm) between the baseframes will provide the standard width of 38" between the inside of the runways.
4. Measure and snap a chalk line parallel to the shop door for the front of the baseframes, a minimum distance of 249 1/8" (6329mm) is recommended.
5. Before proceeding, ensure that once the runways are installed adequate workspace will remain in front of the lift. Refer to the minimum requirements listed in the installation and operation manual of any alignment equipment as needed.

**Figure 4 – Baseframe Locations**



Refer to the minimum requirements listed in the installation and operation manual of any alignment equipment as needed.

## 7.4 Unpacking the Lift

1. Unpack the console and place it in the desired location at the rear of the lift. The console can be placed on either the left or right hand side of the lift.
2. Unpack the runways and lay each baseframe along the chalk lines.



**Do not remove the individual strapping on the runways until they have been positioned on the chalk lines.**

---

3. Position the baseframes on chalk lines, and ensure that the runways are parallel. Ensure that both the inside dimensions (front and back) of the baseframes as well as the diagonal distances are equal.
4. Remove the remaining packing straps, and remove the hydraulic hoses, polytubes and proximity switch wires from under the deck. Hoses and wiring are located under the rear portion of the deck and are factory pre-installed.
5. Inspect lift for damage or any irregularities. If any are found, please contact customer service before proceeding.

---

**Note: Do not pull excessively on the hoses and wiring as it may strain the connections to the baseframe.**

---

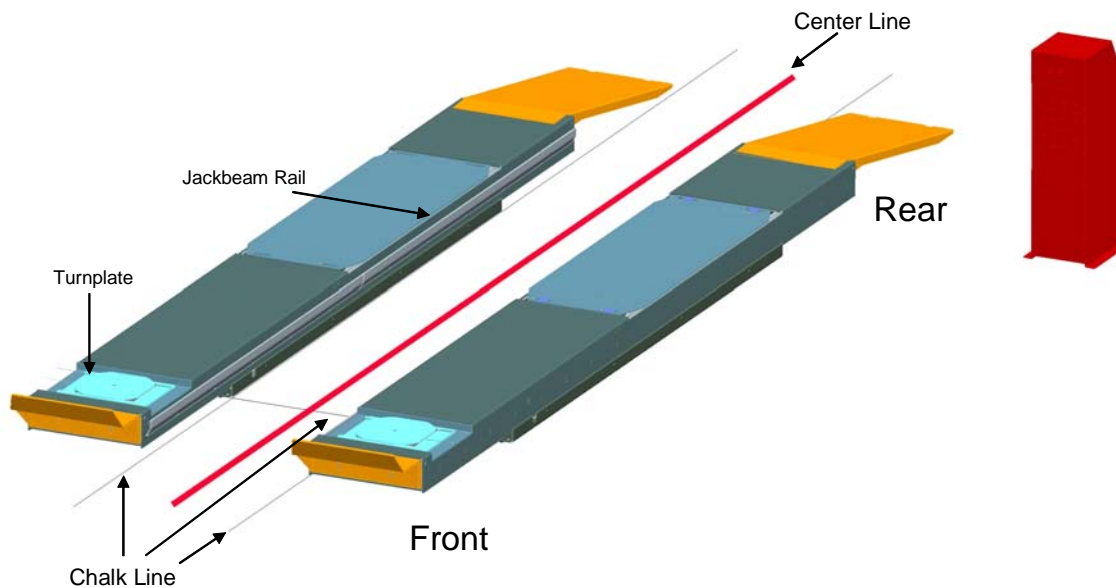

**Ensure that the turnplate pockets are at the front, and that Jack Beam rails for each runway face each other.**

## 7.5 Hydraulic Connections

1. Open the front and rear access covers of the console.
2. Unravel all hoses, air lines, and sensor cables from each runway and connect the hydraulic lines as shown in Figure 5. Save the caps from the hydraulic lines for capping other fittings mentioned in the next step.

- **Always make sure that the connections are clean to avoid contaminating the hydraulic system.**
- **Do not kink hydraulic hoses or air lines.**
- **Do not remove hydraulic fittings while under pressure**

3. The primary supply lines and equalizing lines from each runway are:

**Left Side (L):**

CL

EQL + 22718

(“C” for “Cylinder” and “EQ” for “Equalize”)

**Right Side (R):**

CR

EQR + 22719

4. The 3/8” polytube return lines in the baseframes should be joined inside the console using a 3/8” “T” connector (**Figure 5**) from the hardware kit. To connect the “T” connector to the tank, cut off approximately 6” to 8” (152.4mm to 203.2mm) from either polytube supplied. Next, connect the other end of the tube to the pump connection marked T (Tank) (**Figure 6**)



**Figure 5 - "T" Connector**

FRONT

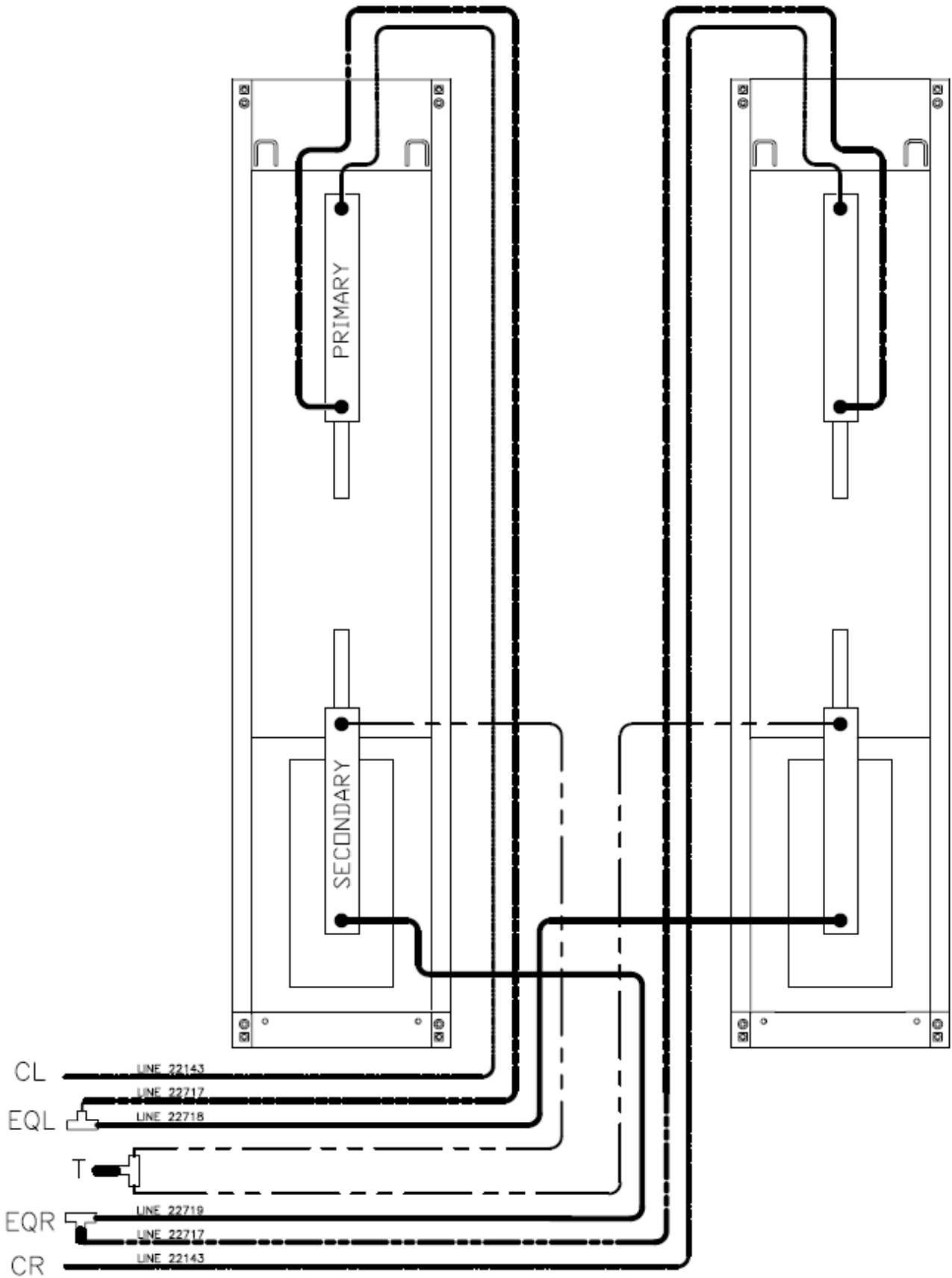

Figure 6 - Hydraulic Connections



## 7.6 Air Safety and Auxiliary Air connections



**WARNING! WEAR SAFETY GOGGLES AND PRACTICE CAUTION WHILE WORKING WITH COMPRESSED AIR.**

1. Uncoil the 1/4" polytube under each deck that is connected to the air release cylinder. Route this line to the 'y' connector in the console.
2. The 3/8" polytube for the auxiliary air connections is coiled under the right side runway. Route this hose to the console and connect it to the tee fitting at the back of the FRL unit.
3. A 3/8" NPT fitting (**not supplied**), is needed to connect shop air supply to the Air Filter / Regulator/ Lubricator Unit. Connect air line through cutout in back of console, into FRL unit.

**IMPORTANT: Shop air must be connected to the inlet port at the FRL unit in the console, in order for lift to operate.**

4. Fill the Lubricator Reservoir with Snap-On Air Motor Oil #IM6 or Equivalent.
  - The console is equipped with an Air Filter / Lubricator / and Regulator to ensure a clean air supply is provided to the safety release cylinders, jackbeams, and any other air tools connected to the lift. The Air Regulator should be set between 90-120 psi.

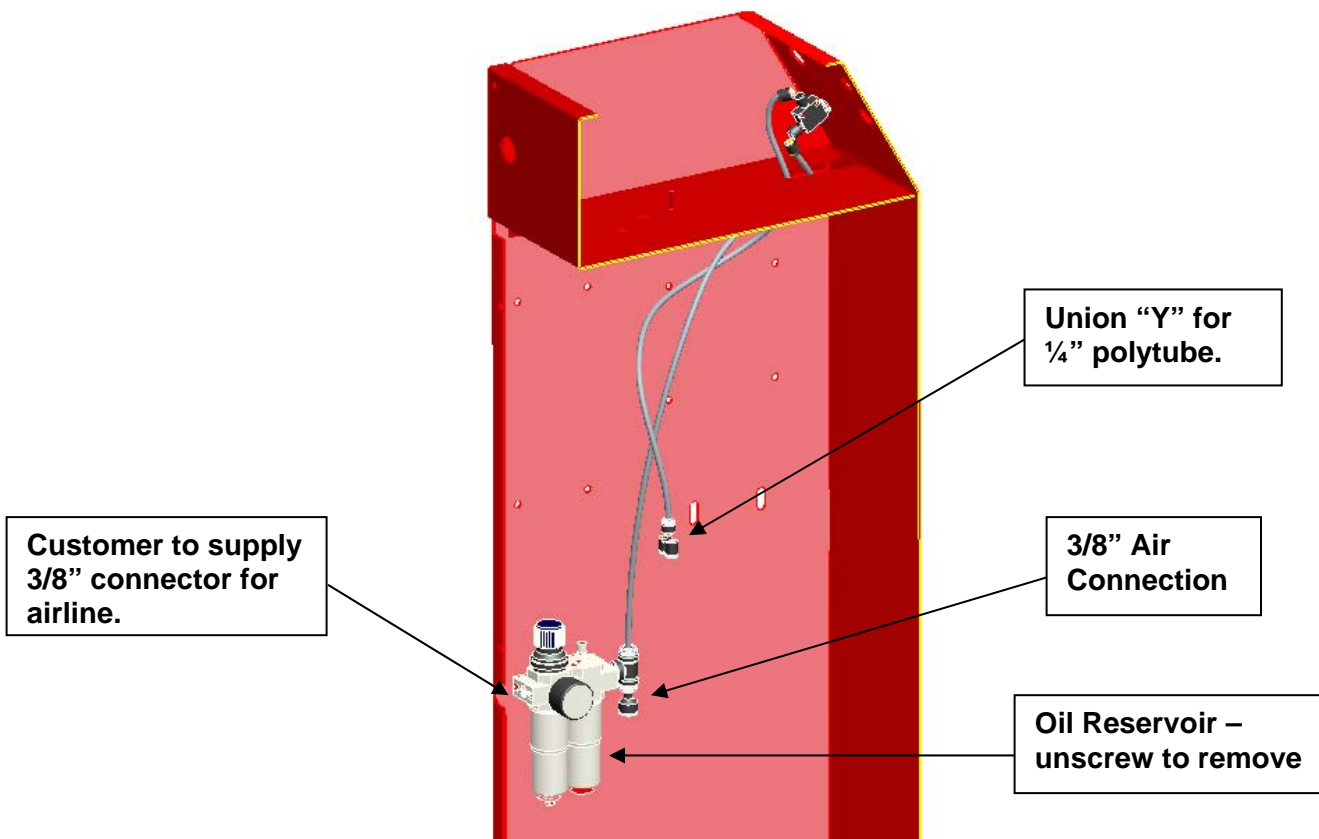

5. After connecting the main air line, check the air system for any leaks.

FRONT

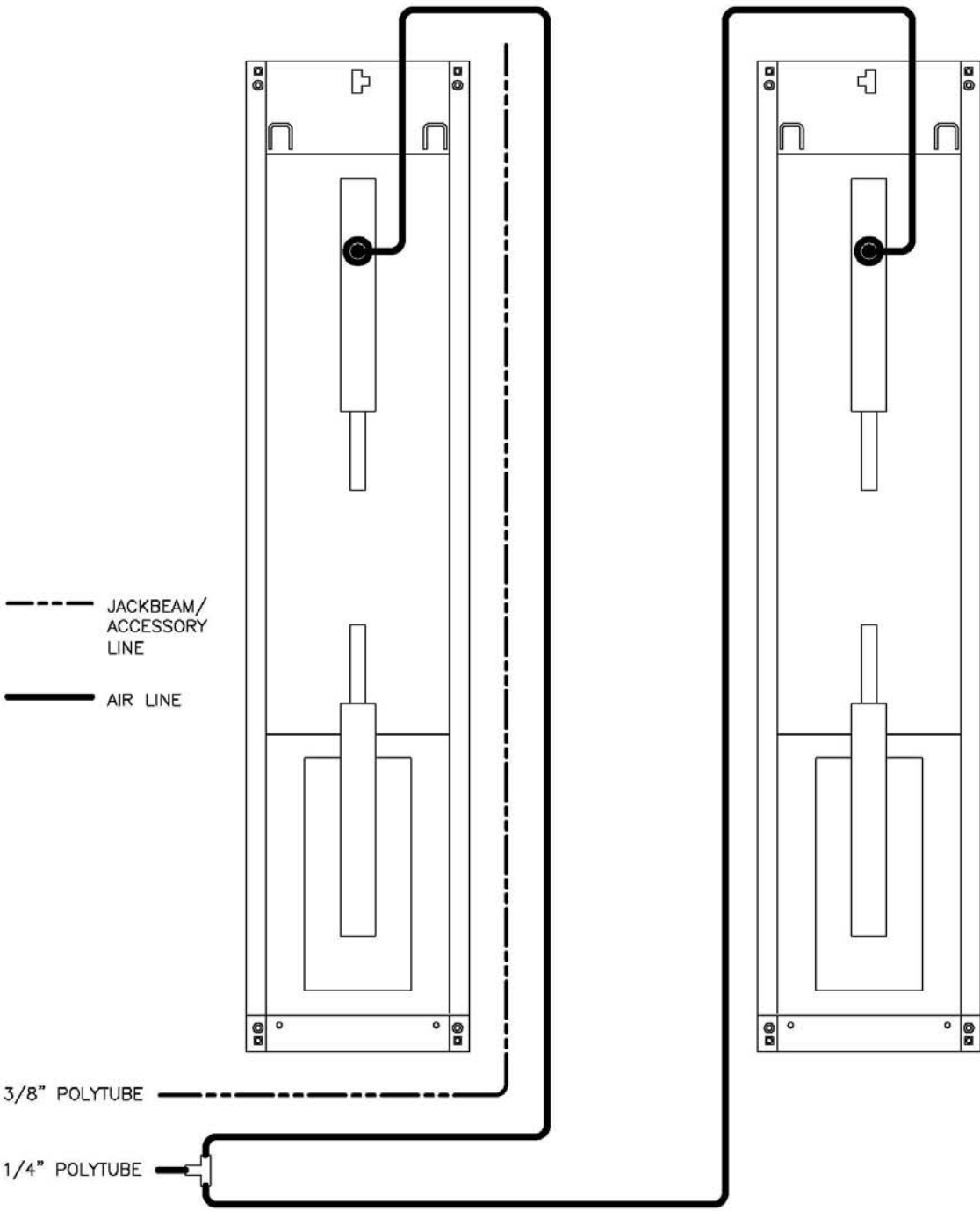

Figure 7 - Air Safety & Auxiliary Air Connections

## 7.7 Pneumatic Sensor Connections

There are three (3) pneumatic limit switches on this lift. Each runway is outfitted with an individual equalizing pneumatic switch mounted on a bracket located under the front of the runway. The third pneumatic switch, used for upper limit detection, is located under the rear slip plate area on the left scissor assembly.

Each Pneumatic Switch has a supply line and return line.

1. The equalizing pneumatic switch and upper limit pneumatic switch on the left side scissor assembly are supplied by the 3/8" jackbeam air line (Figure 8).
2. The equalizing pneumatic switch on the right side deck assembly is supplied by the main air supply in the console. Connect the supply line labeled "EQ. SUPPLY" as shown in Figure 9.

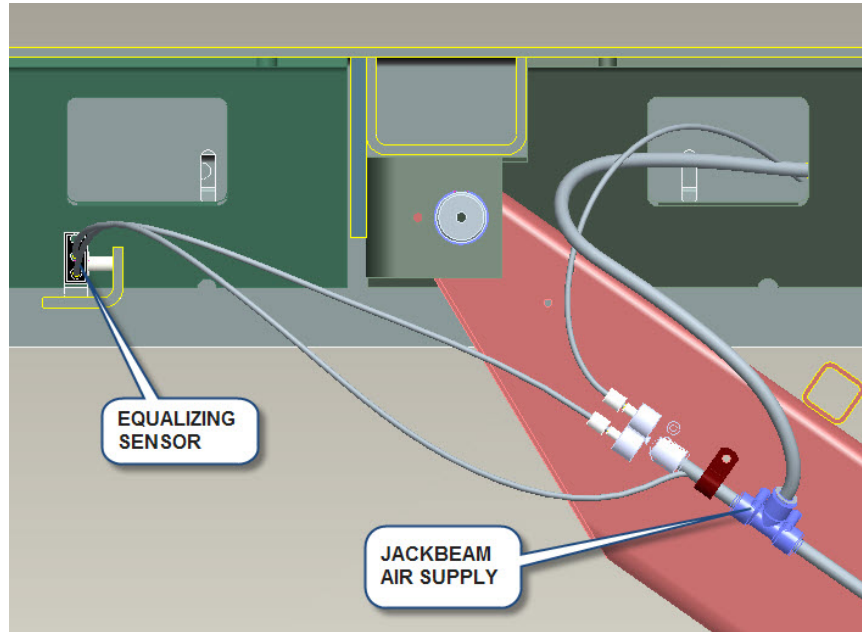

Figure 8a - Equalizing Pneumatic Switch. (View under LS Deck - Front)

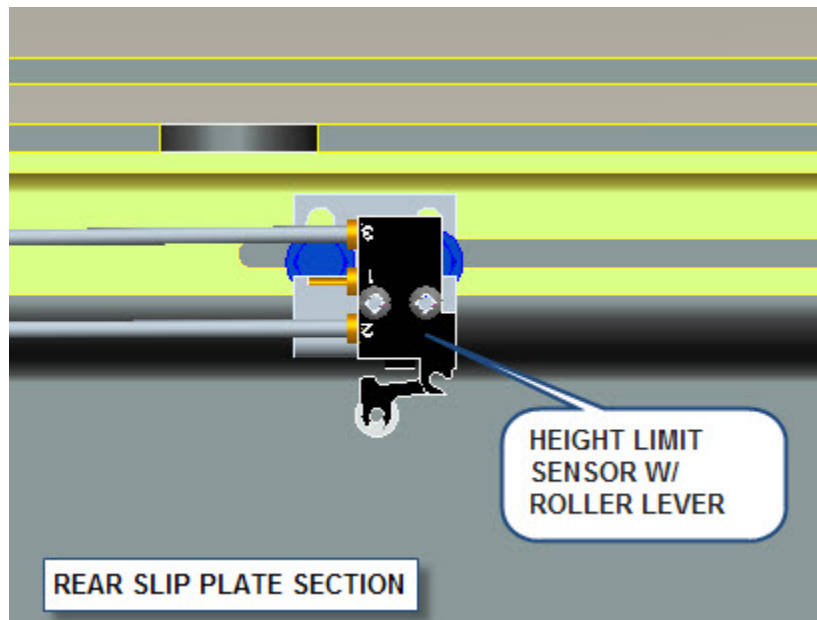
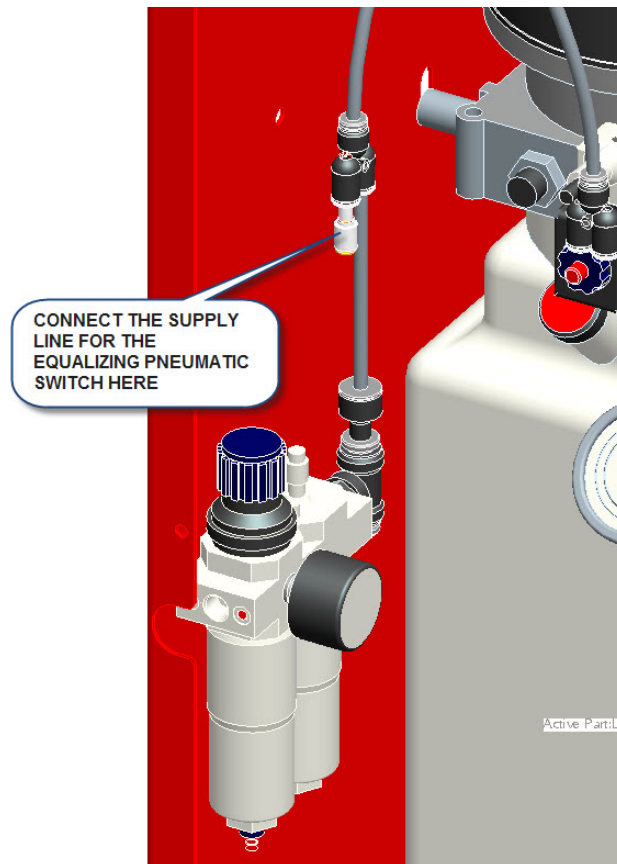
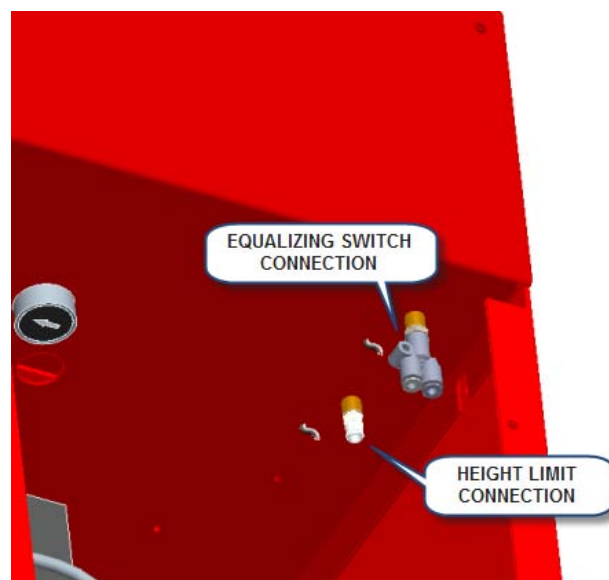

Figure 8b - Upper Limit Pneumatic Switch. (View under LS Deck - Rear)



**Figure 9 – Right Side Equalizing Limit Pneumatic Switch (Console)**

3. The two (2) equalizing pneumatic switch return lines, labeled “EQ. RETURN”, are connected to a union ‘Y’ fitting in the console (Figure 10).
4. The upper limit pneumatic switch return line, labeled “LMT RETURN”, is connected to the pressure switch fitting in the console (Figure 10).

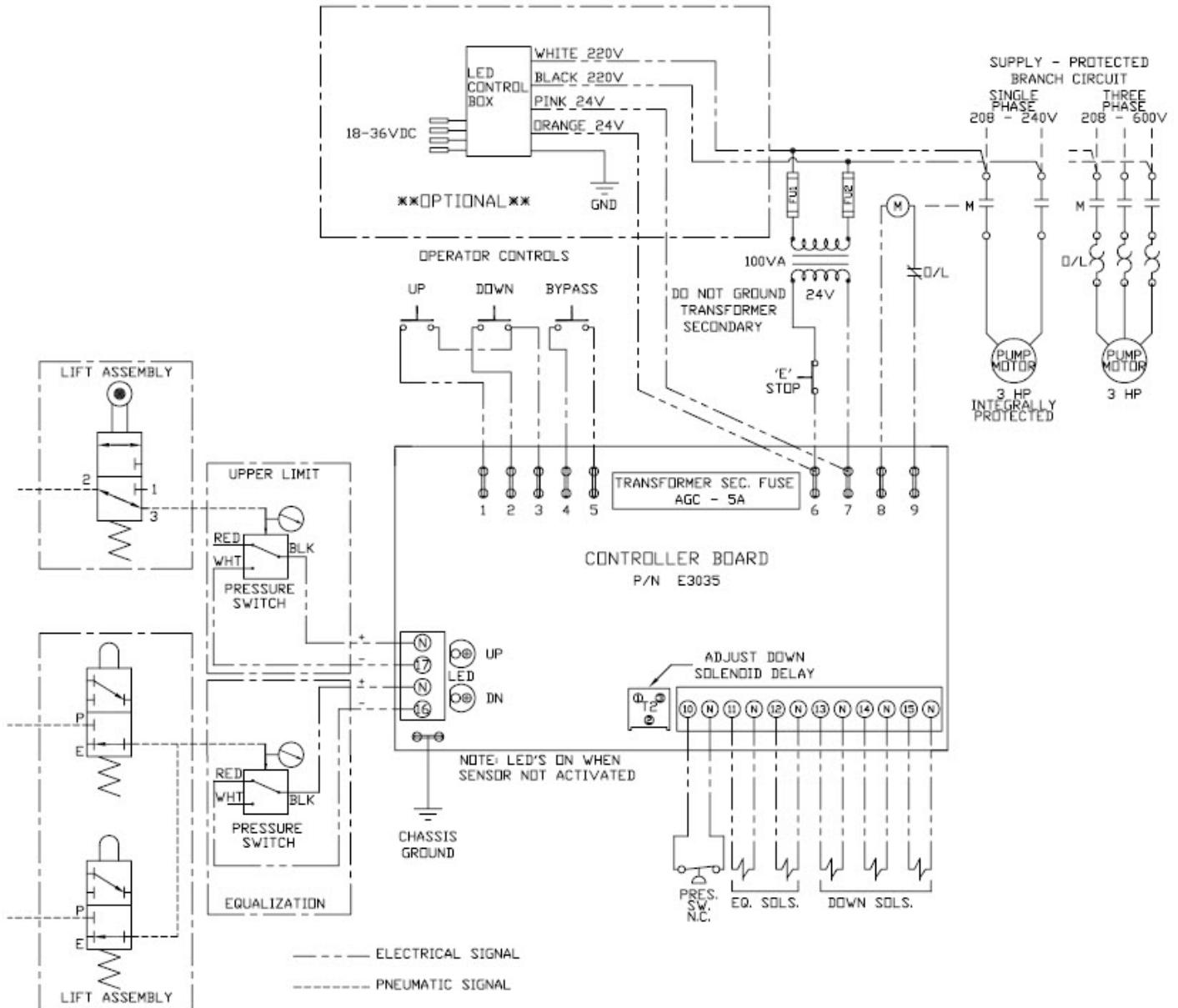

**Figure 10 – Pneumatic Switch Return Line Connections (Console)**

## 7.8 Electrical Connections



**DANGER !** – Ensure that electrical connections are completed by a licensed electrician. Electrical shocks can cause serious injury or even death.



**Figure 11 - Console Circuit Connections**

**\*\* Optional for locking and lights.**

**NOTE:** Overload fuse does not come with single phase power unit

**NOTE:** Optional Voltage and Phase power units will include separate wiring diagrams.

## 7.9 Initial Operation

1. Add hydraulic fluid to reservoir (ISO 32 10wt). Oil capacity for the lift is approximately 6 gallons.

**IMPORTANT: Shop air must be connected to the inlet port at the FRL unit in the console, in order for lift to operate.**

2. Raise lift to 2 ft, lower and repeat 3 to 4 times, using “UP” and “DOWN” controls on the front of the console.

**\* During this stage the lift is not yet full of oil. During the following steps, one side of the lift may raise higher than the other.**

3. Using the “BYPASS” button inside the console, start raising the lift to the last lock position as shown in Figure 12.

Monitor the fluid level during this procedure. At approximately half way, add 10 liters of oil to the reservoir. Continue to raise the lift.

**NOTE: Ensure the gauges inside the console are monitored and pressure does not reach 1000 psi. If 1000 psi is reached, lower the lift onto the locks to relieve the pressure. Continue to raise the lift until both sides of the lift are on the last lock position. (Figure 12)**

**IMPORTANT: The unit must be on the last locking position to bleed the lift.**

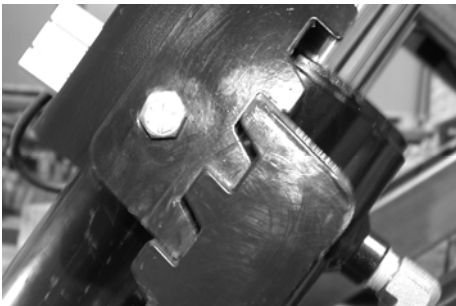

Figure 12-Safety lock position for bleeding.

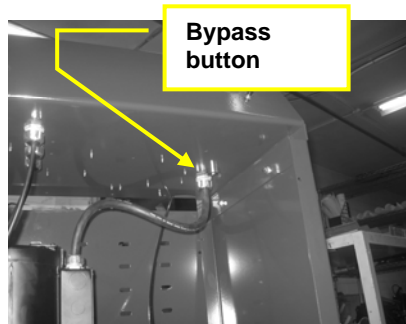

Figure 13- Location of bypass button.

4. BLEED THE SYSTEM: Once the lift is placed on the last safety position, remove the polytube return lines, at the tee fitting (Figure 5) and place them into a funnel over the reservoir. Press the bypass button until a clear stream of oil is flowing from the return lines. Release the bypass button and wait for 5 -10 seconds and continue to bleed. Repeat this “wait and bleed” procedure 5 times or until air is no longer visible in the return lines. Connect polytube lines back to the tee fitting.

5. RELEASE THE SAFETY LOCKS: Place a rag or drip pan directly under the secondary cylinder and remove the 90 deg. push lock fittings on the top of the secondary cylinders (see Figure 14). Cap the port using the plugs provided.



6. Holding the air safety release button on the console, raise the lift using the “BYPASS” button until the safety locks disengage. **DO NOT BUILD PRESSURE OVER 1000 PSI.**

7. Lower the lift to the next safety lock. Remove the plugs and reinstall the 90 deg push lock fittings. Lower the lift to a comfortable working height and continue the installation.



Figure 14- Remove fitting.

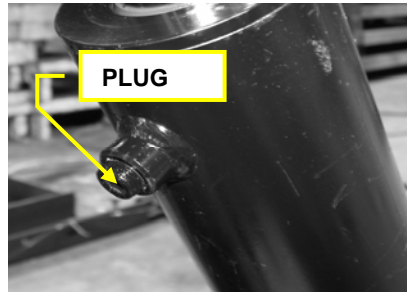

Figure 15- Cap port using plug provided.

## 7.10 Equalizing Function Check

### Check:

To verify that the pneumatic switches are functioning, remove the rear panel on the console and locate the five (5) Din Connector/Solenoid assemblies; (four (4) on manifold block and one (1) on the pump). When the lift reaches its fully lowered position, these din connectors will emit a red light for 3 to 5 seconds.

If this does not occur, check the pneumatic connections at the sensors and at the console.

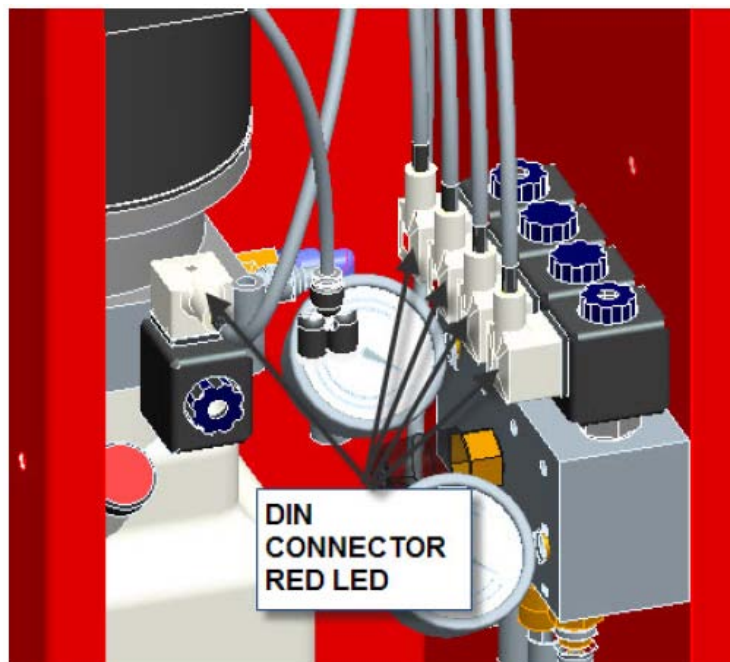

## 7.11 Maximum Height Adjustment

The lift has been pre-adjusted at the factory to a 72" working height. If a lower height limit is required, the system can be adjusted to a minimum of 43".

1. Raise lift to full height by pressing the up button (do not press the by-pass button).
2. The limit switch (see Figure 16) should automatically stop the lift once the 72" working height (bottom of baseframe to top of runway) is reached. **NOTE: Switch must be installed in front of the cross-tube.**
3. Lower the lift to the desired working height ensuring the safety locks can be disengaged.
4. Loosen the 1/4" adjustment bolts and slide the limit switch and bracket assembly towards the scissor cross-tube until the roller lever on the switch is fully depressed. **NOTE: Switch must be installed in front of the cross-tube.** Hold in place and tighten 1/4" bolts.

**CHECK:** Lower the lift to the ground, then raise until the lift stops. Perform this function a few times to verify the upper limit is set correctly.

**NOTE:** Make sure locks can be disengaged at the maximum or desired height.

### UPPER LIMIT PNEUMATIC SWITCH

**LOCATION:** Underside of Driver Runway.

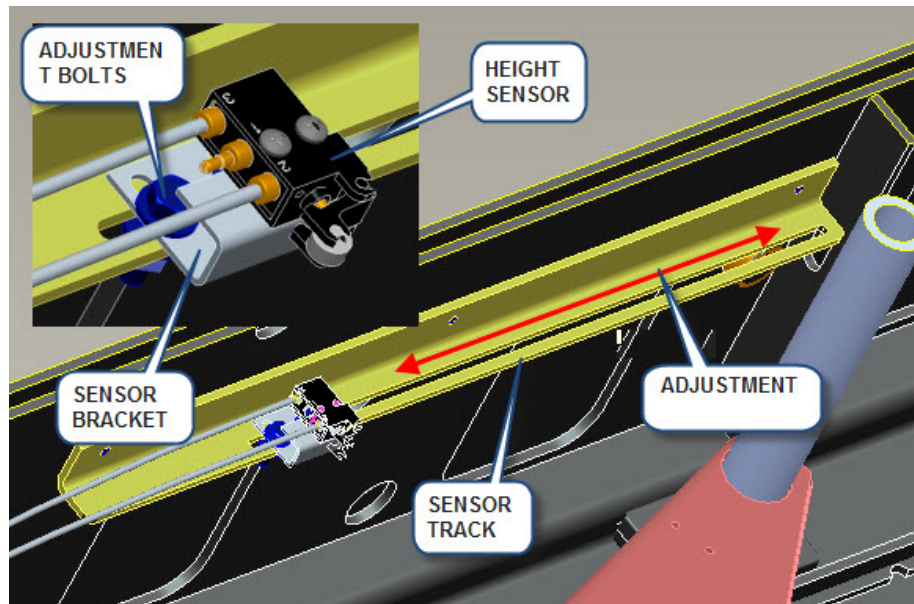

Figure 16 - Upper limit proximity sensor

### **NOTICE**

The limit switch should never allow the working height to be above 72". If the automatic stop height is above 72", damage or failure of the hydraulic seals in the cylinder can occur.



## 7.12 Level and Support



**NOTICE** - CORRECT LEVELING IS IMPORTANT TO ENSURE THE PROPER OPERATION OF THE LIFT. TAKE PRECAUTIONS TO ENSURE ACCURATE LEVEL READINGS WHEN PERFORMING THIS PROCEDURE

Side-to-side leveling measurements should be taken off the baseframe, and measurements should be taken on each baseframe as well as between the two baseframes. Front-to-back level measurements should be taken on the runways.

1. Press the up button and raise the lift to the fully extended operating position. Check the location of the baseframes compared to Figure 4, and make minor adjustments as required.
2. Level the baseframes using the 5/8" leveling bolts provided at each of the four (4) corners.
3. Use shims provided to support under glide block area of baseframe and under front hinges. See **Figure 17**.

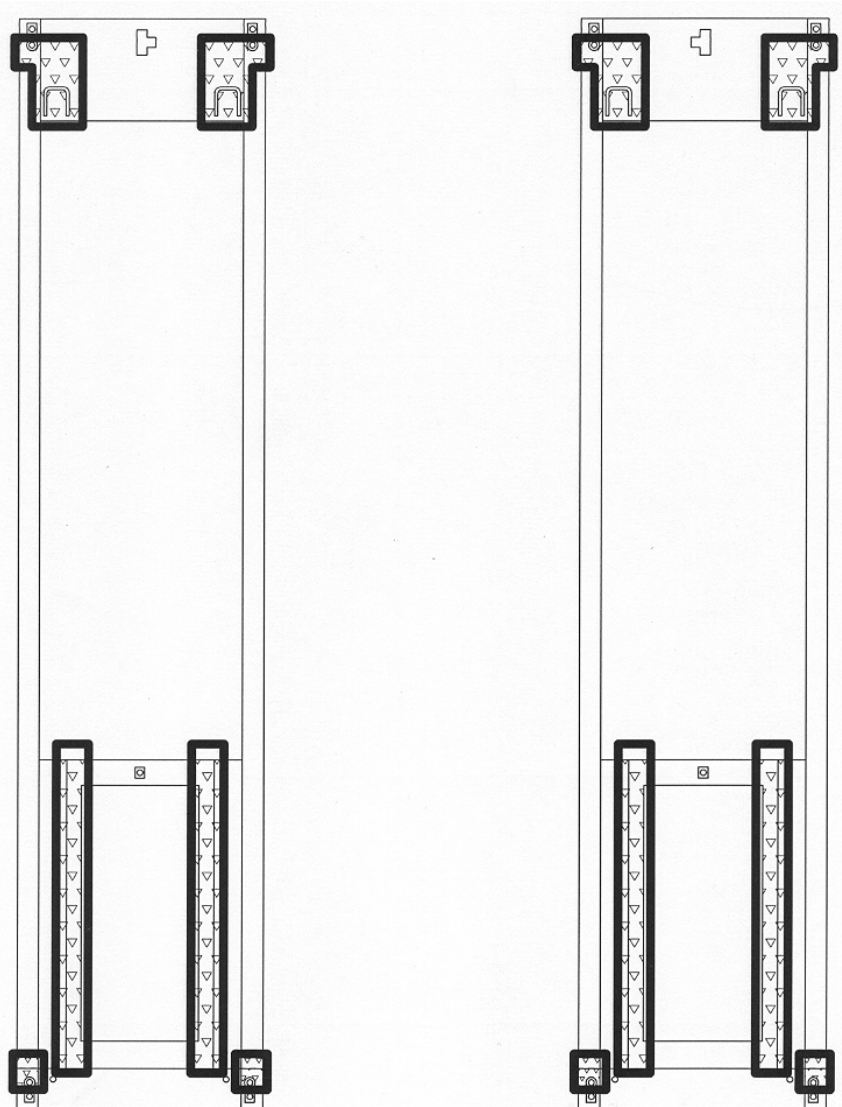

Figure 17 - Shimming

4. Verify that the baseframes are level side-to-side and that the runways are level front-to-back. The front turnplate and rear slip plate are the areas of interest. Check that the spacing between the runways is as desired, and that this spacing is equal at both the front and rear of the lift. Check that the diagonal measurements between opposite corners of the baseframes are equal. Lower and raise the lift and repeat these measurements.
5. Adjust the 3/4" support bolts on the four (4) corners of the baseframes to level the runway at fully collapsed position.
6. Once lift is level, back off 5/8" leveling bolts so that the base is firmly sitting on the shims. Re-check to make sure the lift is still level and shims are holding properly.  
Note: These bolts must be removed once the shims are installed under the base correctly (same as the center bolt on the base).

## 7.13 Anchoring Procedure



**CAUTION!** WEAR SAFETY GOGGLES AND PRACTICE CAUTION WHILE DRILLING CONCRETE.

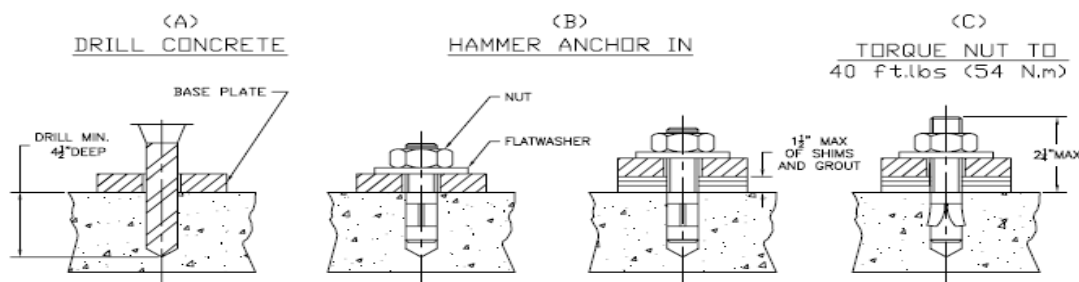

**Figure 18 – Anchoring**

1. Lower the lift and measure the distance between the Jackbeam rails at front and rear of the lift.
2. Raise the lift to full height and repeat the measurements, and ensure there are no differences.
3. Using a rotary hammer drill and a 1/2" concrete bit, drill through the floor at each of the four (4) anchor bolt locations on each of the base frames. Refer to **Figure 18**.
4. Assemble the nut and washer onto the 1/2" x 4 1/2" long wedge anchor bolts supplied. A minimum of six threads must be visible below the surface of the nut.
5. Clean out the drilling dust from the holes and hammer in the anchors until they make contact with the baseplate. **Hand tighten all anchor bolts.**
6. Torque all anchor bolts to 40 ft-lbs.
7. Position the console in the final desired location. Using a rotary hammer drill and a 1/4" concrete bit, drill and anchor the console to the floor using the Nail in Anchors located in the hardware kit.
8. Use the line covers to protect all cables, hoses, and wiring running to the lift. Using a rotary hammer drill and a 1/4" concrete bit, drill and anchor the line covers using the nail in anchors located in the hardware kit.

If anchor bolts do not tighten to 40 ft-lbs. OR project more than 2 1/4" above the concrete surface, the concrete should be replaced by an appropriate concrete pad.

## 7.14 Grouting Procedure (Optional)

1. Pour grouting under the load area of each base frame as shown in **Figure 19**. Ensure that grout is evenly distributed under the frame and finish the edges with a 45 degree chamfer. Refer to specific grouting instructions on the package. Leave a drain area to allow any liquids to escape.
2. **GROUTING MUST FULLY CURE BEFORE PROCEEDING.** Do not operate the lift while grout is curing. Refer to instructions on the package for recommended cure times. [Non-Shrink Grout (3000psi min. in 24hrs, 7000psi min. in 30 days)]

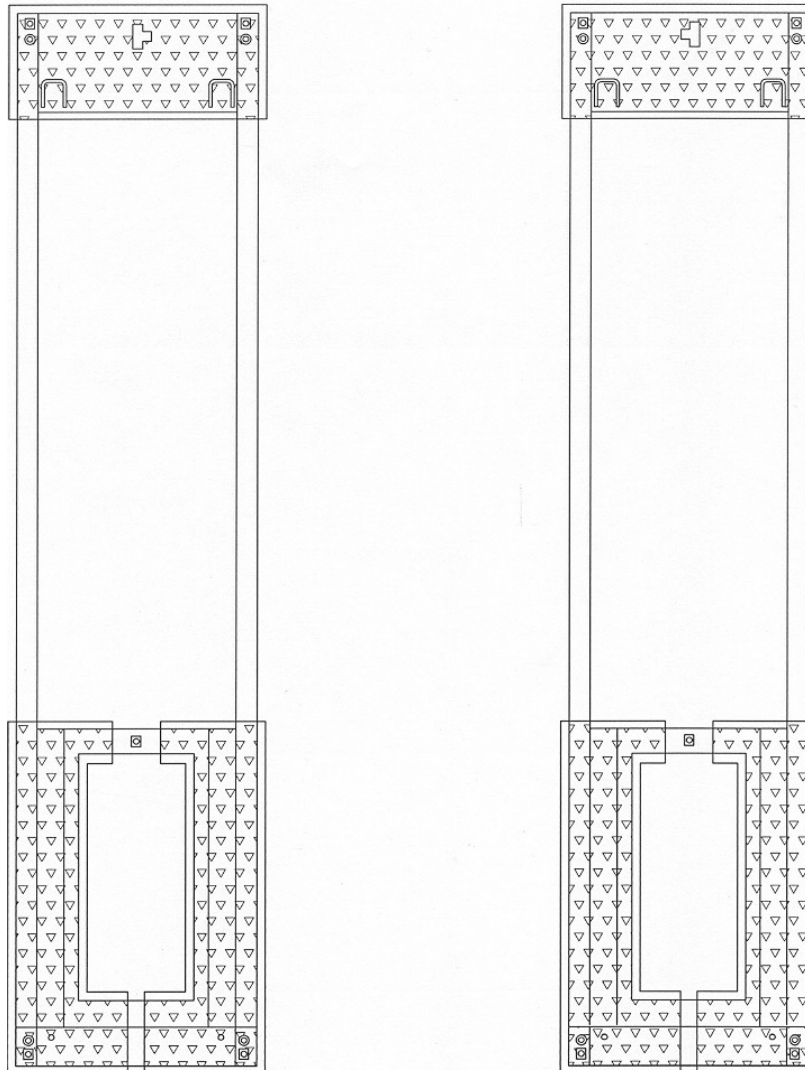

**Figure 19 - Grouting Locations**

## 8.0 ACCESSORY INSTALLATION

1. Install the front runway stops located in the accessory box using the ½" hex bolts, washers, lock washers, and hex nuts located in the hardware kit.

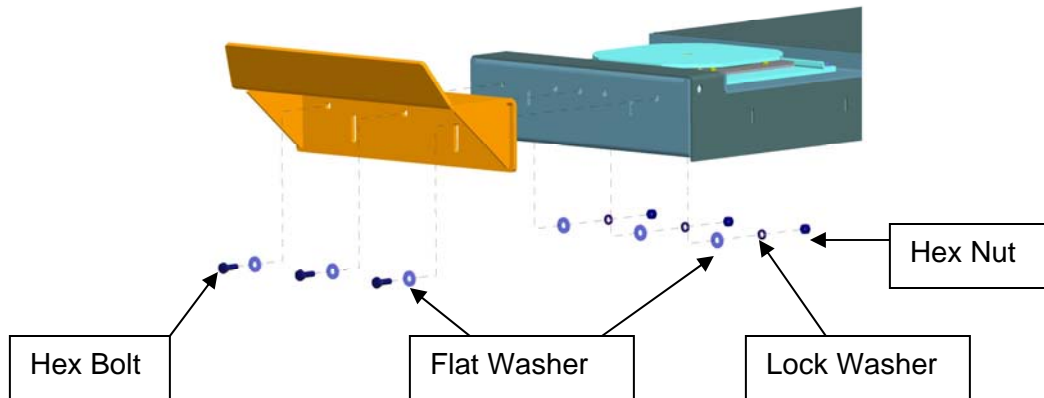

The runway stops are designed as a secondary means to restrain a vehicle from inadvertently rolling off the runways. Property damage and physical injuries may occur if this warning is not adhered to.

---

2. Install the mounting bracket and then the rear approach ramps using the Approach Ramp Pins located in the accessory box, and the hex head bolts, flat washers, lock washers, hex nuts and cotter pins located in the hardware kit.

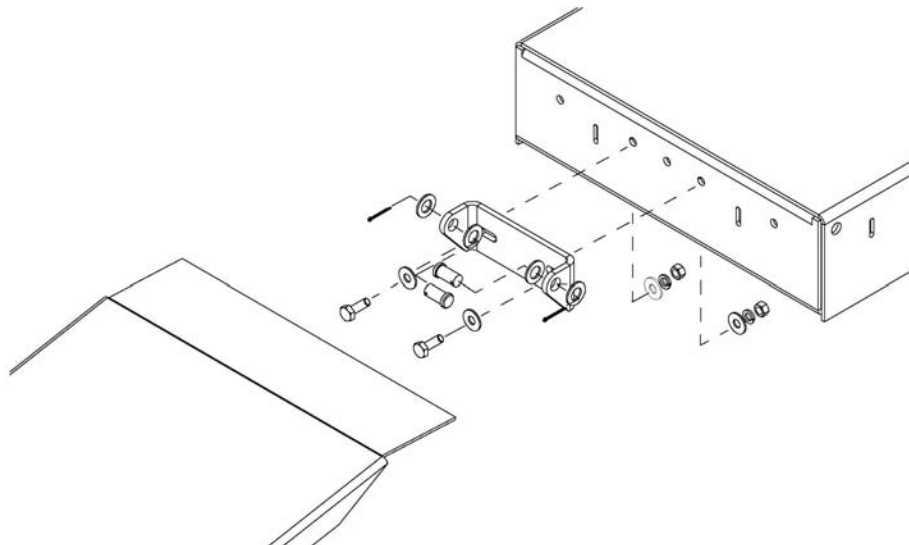

3. Install Jackbeams with reference to the Jackbeam user manual.

4. Position the moveable workstep in the desired location. There are slots along the span of each runway where the workstep can be mounted. When not in use, the workstep can be stored under the front section of the runway.

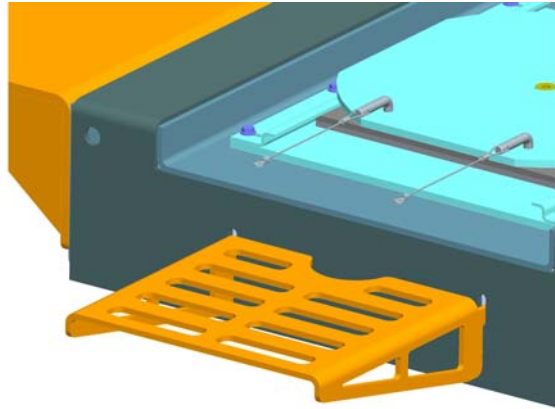

---

**WARNING!!** ENSURE THE WORKSTEP IS FULLY ENGAGED PRIOR TO USE. IF MORE THAN ONE WORKSTEP IS IN USE, DO NOT TRY TO STEP ACROSS OR JUMP FROM ONE STEP TO ANOTHER. NEVER USE THE WORKSTEP WHILE THE LIFT IS IN OPERATION. SERIOUS INJURY COULD RESULT FROM IMPROPER USAGE OF THE WORKSTEPS.



**WARNING!** WORKSTEP MAXIMUM CAPACITY IS 250 LBS.

**WARNING!** FOR FLUSHMOUNT INSTALLATIONS ENSURE WORKSTEP IS REMOVED BEFORE RAISING OR LOWERING THE LIFT.

---

## 8.1 Installation of Line Covers

1. Install line covers once console is installed and hydraulic lines are routed.
2. Position line cover "C" behind the right baseframe as shown.
3. Cut 11-3/8" off length of line cover "B" and position it behind the left baseframe as shown. Do not discard the cut piece as it will be used in step 4.

**Note: It is important to create square cuts. The use of a sliding miter saw or a simple miter box is recommended.**

4. Position the line covers "A" between line cover "C" & "B" and mark where they overlap. Cut each to fit.
5. Using the remaining piece of Line cover "B" from step 2, place as shown below.
6. Position line covers "D" to the console. Cut if required.
7. The number along each side of the line covers represents the quantity of fasteners required to secure them in place. Using a 1/4" concrete drill bit, drill holes as required and install the supplied 1/4" x 1" long nail in anchors (6-0141).

**Note: Tapcon or equivalent concrete screws can be used as an option for future removal.**

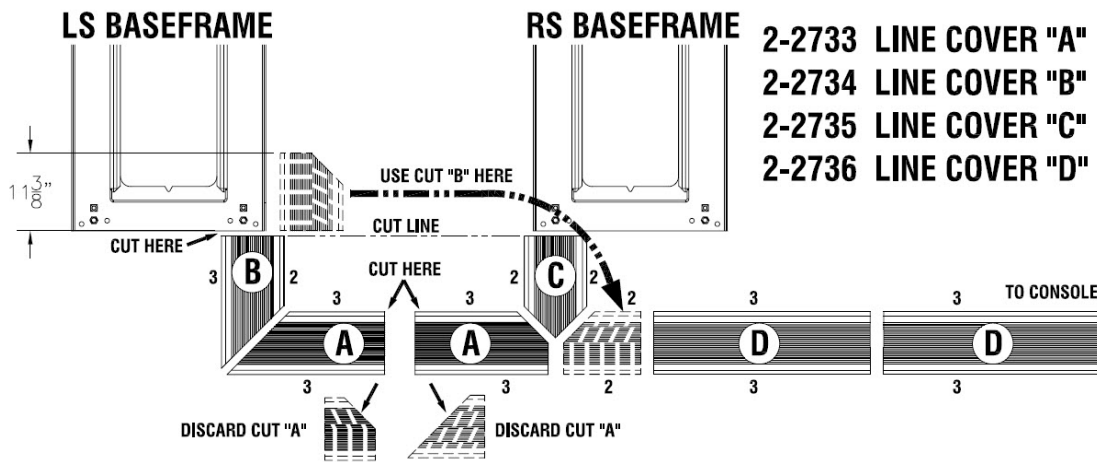

**Optional:** To locate the consoles on left side of lift, the setup is mirrored with the following changes to the above installation steps:

- Step 3 – use line cover A instead of B.
- Step 4 – use (2) of line cover B.
- Step 5 – use remainder of line cover A from step 3.

**Note: If baseframe is shimmed to a point where the line cover does not sit flush due to interference with hoses, the line cover can be heated with a heat gun and then placed over the hoses for a cleaner look.**



## 9.0 LOCKING FRONT TURNPLATES & REAR SLIP PLATES (OPTIONAL)

### 9.1 Installation of Front Turnplates



Avoid inserting fingers in the front alignment pan cut-out, if position of the turnplate assembly exposes such openings.



Ensure that air supply to the lift is turned off and no person is operating on the console during maintenance of clamping elements of the locking system.



During normal use, the front turnplates and rear slip plates may move rapidly, when locking system is activated. This creates pinch points for your fingers or hands. Keep hands clear of these pinch points when lift air supply is connected. No person shall operate console while maintenance or inspection of the slip plates is in process.

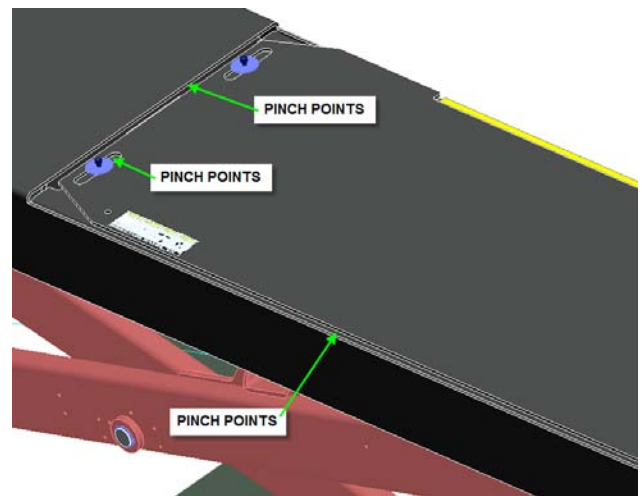
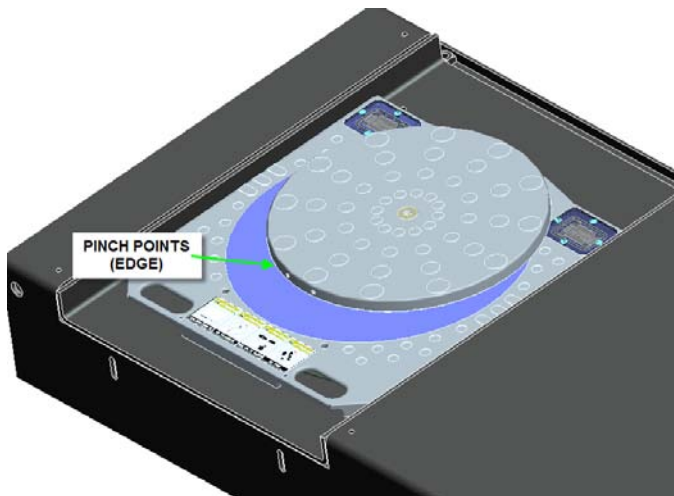

1. Lower lift to a comfort height.
2. Place each front turnplate assembly, one by one, on the front alignment pan on runway. Moving handles of the turnplates should be oriented to the outside of lift, shown below.

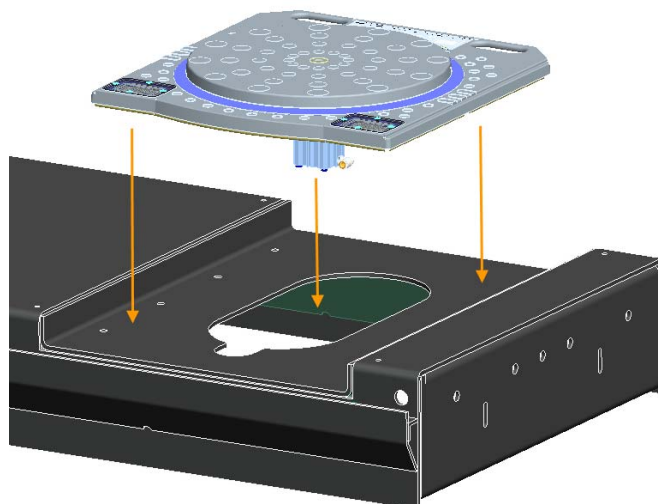

---

Ensure that the locking system components on the bottom of the turnplate (air cylinder, fittings, and plastic clamping parts) are not hit against the runway during placement.

---

3. Verify that the turnplate assembly is completely seated in the front alignment pan. Gently slide each turnplate in the alignment pan, left and right, to verify that they can be positioned for different car widths. Do not hit plastic locking ring forcefully against the edges of the cut-out in the front alignment pan.
4. Connect free ends of front air lines to the turnplate locking cylinder: blue air line to the cylinder port marked with a blue dot and red air line to the cylinder port marked with a red dot [Figure shown below].
5. Plug the electrical connector on the turnplate light cord into the electrical connector on the cable at the front.

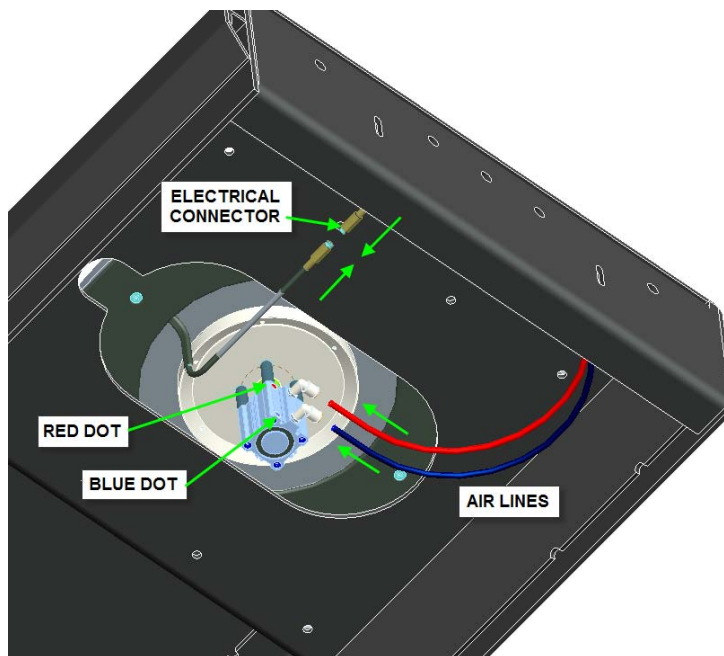



## 9.2 Console Connections for Locking & Lights

### Locking & Light System

1. Connect the (2) red & blue polytubes from lift to corresponding “y” fitting in the console (see Detail C).
2. Connect the 4mm polytube labeled “Return” to pushlock fitting on the LED driver box. Connect the other 4mm polytube labeled “Supply” to the pushlock “Tee” w/ reducer (see Detail “A”)
3. Connect the (2) red & blue female electrical connectors from lift to corresponding red & blue male electrical connectors from the LED driver box (see Detail B).

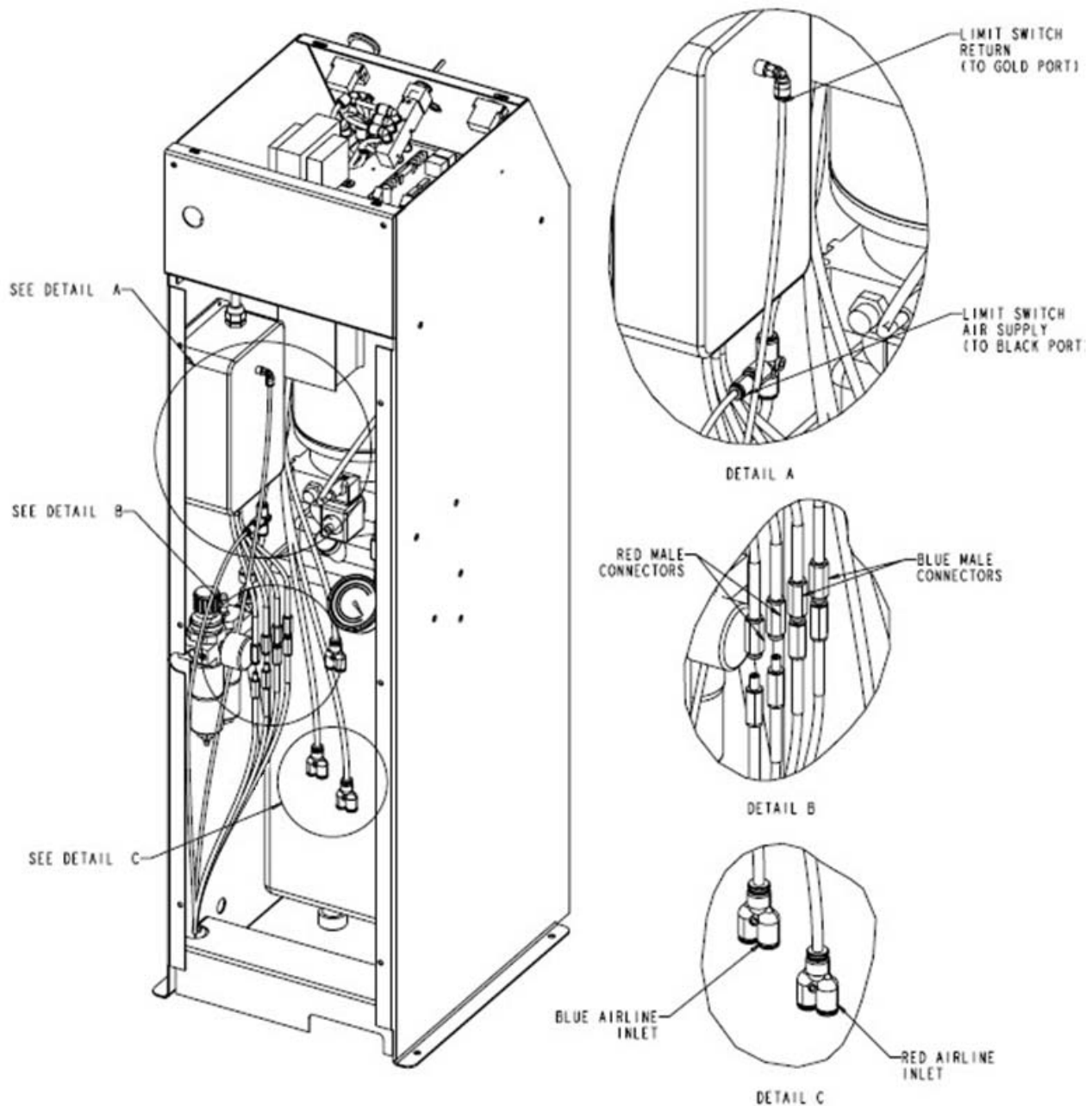

4. Once all connections are made, test system as follows:

- a. **Light System – Lift must be fully collapsed.** Start raising lift. At approximately 30” from the ground, the lights will illuminate. If not, please check that the 4mm polytube connections are correct as they may be reversed.

Comparable to the Upper Limit System (see [Section 7.7](#)), the Light kit is turned on by a similar method. This system will have its own Cam and Sensor, located on the upper hinge at the front right side runway.

**NOTE:** Unlike the Upper Limit System, this system is not adjustable and is factory set.

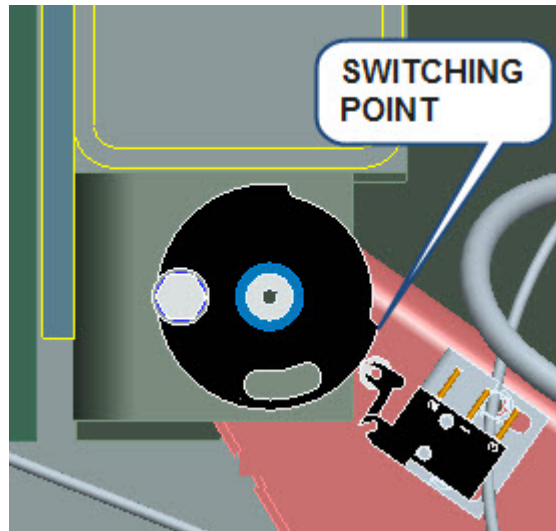

- b. **Locking System** – On front of console, switch the Slip Plate lever to “Unlock”. All locking plates should be free to move, please verify. Now switch the lever to “Lock”, all locking plates should be centered and locked, please verify. If not, check that all polytube connections are correct and there is 90-120 psi of air pressure.

## 10.0 FINAL PROCEDURES

### 10.1 Check of Assembled Lift

1. Final dimension check after anchoring. \_\_\_\_\_
2. Check for air and hydraulic leaks. \_\_\_\_\_
3. Re-check level of decks, front to rear, side to side. \_\_\_\_\_
4. Check all fasteners, tighten if necessary. \_\_\_\_\_
5. Check torque of anchor bolts (Sect. 7.12) \_\_\_\_\_
6. Operate lift to full stroke then lower to ground while checking for proper functionality. Ensure Safety Release is operational. \_\_\_\_\_
7. Ensure Customer Care Kit is complete and given to operator. \_\_\_\_\_
  - a. Operation Manual \_\_\_\_\_
  - b. ANSI / ALI Lift It Right Manual \_\_\_\_\_
  - c. ANSI / ALI Safety Tip Card \_\_\_\_\_
  - d. ANSI / ALI ALIS Safety Requirements for Installation and Service of Automotive Lifts \_\_\_\_\_
  - e. ANSI / ALI Quick Reference Guide \_\_\_\_\_
8. Ensure Oil has been added to the Filter / Regulator / Lubricator (Sect. 7.6) \_\_\_\_\_
9. Upper limit switch and height shut off \_\_\_\_\_
10. Equalizing switch operation \_\_\_\_\_
11. Train end user on operation of lift. \_\_\_\_\_

### 10.2 Operation Test with Vehicle

1. Lower lift to the ground. (Make sure Green Light is OFF) \_\_\_\_\_
2. Drive vehicle on to lift. \_\_\_\_\_
3. Raise the lift, and lower onto 3-4 different locking positions until the full lifting height is reached. Check that all locks are working correctly. \_\_\_\_\_
4. Lower lift to the ground and drive vehicle off lift. \_\_\_\_\_

**If any problems occur during the final checkout or operation of the lift please contact customer service at 1-800-225-5786**

## 11.0 LIFT OPERATION

### 11.1 Raising the Lift

1. If the lift is equipped with sliding Jack Beam(s), be sure that the Beam(s) are positioned at the front or mid travel of the lift, fully down, and with the risers removed and stored. Never store Jack Beams at the rear of the lift.
2. Ensure that the lift is fully lowered before attempting to load or unload a vehicle.
3. Ensure that locking pins are in the front turnplates and rear slip plates before driving a vehicle onto the lift.
4. Position the vehicle on the lift ensuring the resulting load on the deck is distributed as evenly as possible. Under no circumstances should a vehicle be lifted if the weight distribution is unbalanced by more than 10% on either side. Maximum wheelbase for this lift is 176”.

**ATTENTION:** THE VEHICLE IS POSITIONED CORRECTLY WHEN THE DISTANCE FROM THE CENTER OF THE TIRES TO THE INSIDE EDGE OF THE RUNWAYS IS EQUAL ON BOTH RUNWAYS, FOR BOTH THE FRONT AND REAR TIRES.

5. Chock the vehicle using the wheel chocks provided.
6. Check that there are no obstructions above the lift that could damage the lift or vehicles.
7. Raise the lift by pressing the up button on the control console. Raise the lift past the desired working height until both mechanical safeties are heard engaging. Press the down button to lower the lift down onto both of the mechanical safeties
8. Do not raise or lower the lift with the vehicle on the Jack Beam.



**WARNING! NEVER WORK UNDER A VEHICLE OR THE LIFT UNLESS IT IS POSITIONED ON BOTH MECHANICAL SAFETIES!**

---

### 11.2 Lowering the Lift

1. Check that there are no obstructions under the lift or vehicle. Be sure that the sliding Jack Beams are fully lowered and positioned at the front or mid section of the lift.
2. Raise the lift by pressing the up button until both runways are clear of their mechanical safety locks.
3. Press the air safety release button to release the mechanical safeties.
4. While holding the air safety release button, press the down button and lower the lift to the completely collapsed position.
5. Remove wheel chocks and ensure that locking pins are in the front turnplates and rear slip plates before driving a vehicle off the lift.
6. Be certain that the lift is completely lowered before removing the vehicle from the lift.
7. Do not raise or lower the lift with the vehicle on the Jack Beam.



**ATTENTION: THE OPERATOR MUST ALWAYS KEEP THEIR ATTENTION ON THE OPERATION OF THE LIFT WHILE RAISING OR LOWERING. IF AN OBSTRUCTION IS SEEN, RELEASE BOTH THE AIR SAFETY RELEASE BUTTON AND THE DOWN BUTTON TO STOP THE LIFT.**

---

## 12.0 RECOMMENDED MAINTENANCE

The following maintenance schedule is recommended for ensuring the operation of the lift. A record of maintenance performed should be maintained and any items that resulted in additional service should be noted.

Schedule	Maintenance Required
Daily	Check that the upper and lower glide tracks are clean and free of debris. This area should be checked before raising or lowering the lift.
	Inspect the operation of the lift by raising and lowering the lift fully.
	Check for the proper engagement and release of mechanical safety locks. If bolts are removed for maintenance re-apply LOCTITE #242 before re-assembly
	Check hydraulic lines for leaks and fraying. Frayed hoses must be replaced immediately.
Weekly	Check the fluid level in the reservoir with the lift fully lowered. Top up reservoir with ISO 32 (10 weight) hydraulic oil as needed.
	Check Oil Level in Air Line Lubricator and refill if required (See 11.2)
Monthly	Check anchor bolts for tightness. Torque to 40 ft-lbs if needed.
	Inspect the electrical and mechanical operation of all switches.
	Inspect runway stop fasteners monthly.
5 Year	Change the hydraulic fluid every five years. Use only ISO 32 (10 weight) hydraulic oil.

**NOTE: FAILURE TO FOLLOW RECOMMENDATION MAY AFFECT WARRANTY OF LIFT**

### 12.1 Checking Oil Level for Air Lubricator

1. On the Side of the console is a site window which allows for easy monitor of the oil level in the Air Lubricator.
2. If oil level is low:
  - a. Remove rear panel.
  - b. Unscrew reservoir from the Lubricator.
  - c. Refill using Snap-On Air Oil #IM6 or equivalent.
  - d. Reinstall reservoir.
  - e. Reinstall rear panel.

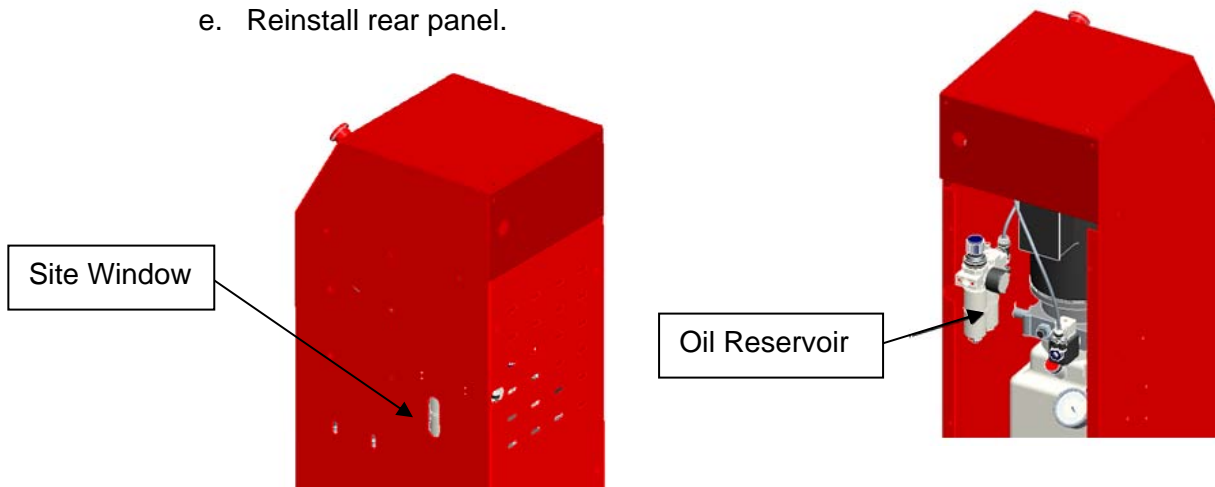

## 12.2 Maintenance of Turnplate & Slip Plate Locking System (Opt.)

1. Observe locking mechanisms with every lift rise for air line connection integrity. Also ensure that no foreign objects are trapped in the clamping components.
2. Once a week inspect the mating conical surfaces of the front turn table locking mechanism. If necessary, blow with compressed air or wipe with a clean cloth any road dust, salt or other contaminants, including liquids. Greasing of these surfaces is not required and not recommended.

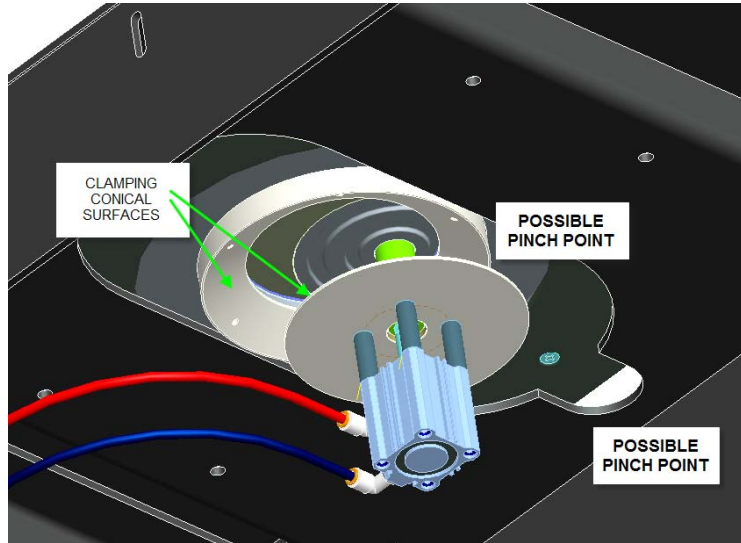

3. After extended use, it may be required that some components of the front turnplate will need replacement, due to normal wear. Please ensure to re-apply *Loctite* where needed, as detailed in the exploded view of the front turnplate – Section 17.1.
4. Once a week inspect locking mechanisms of the rear slip plates. Ensure that clamping jaws are securely attached to cylinder clevises and to pivot pins, and that mounting hardware and air fittings are properly fastened.
5. If replacement of rear clamping components becomes necessary after extended use, re-apply *Loctite* to the threads of the rear cylinder shoulder bolts. Exploded view of one of the 4 rear clamps on the lift is shown in Section 17.2.

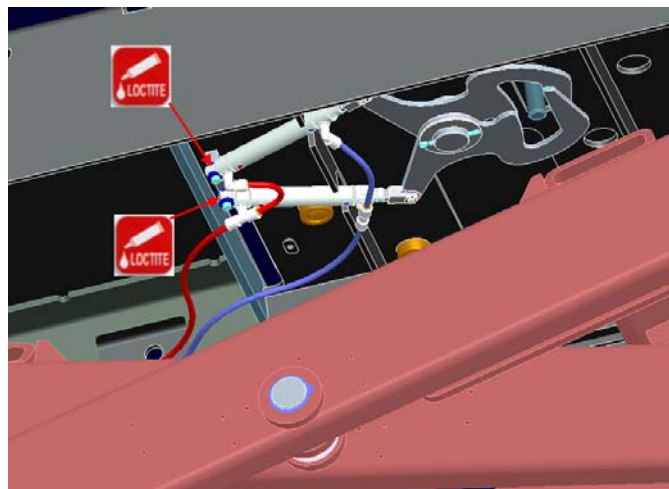

\*\* Re-apply *Loctite* to bolt threads if removing bolts. Tighten shoulder bolts completely in their sockets

## 11.3 Adjustment of Safety Locks

1. Loosen all the bolts with an 9/16" open wrench

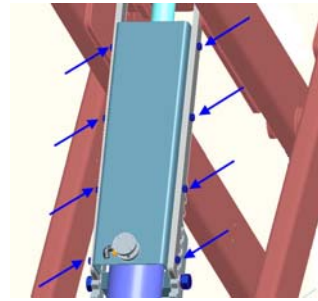

2. Raise lift the lift to its highest position

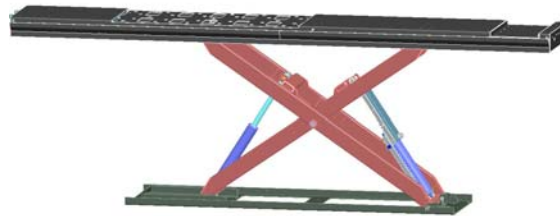

3. Center the top safety rack in between the bottom safety rack.

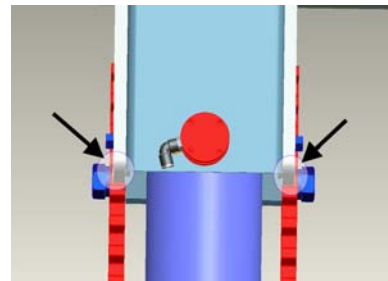

4. Tighten each bolt in sequence as shown in the figure below. Check the alignment after tightening each bolt.

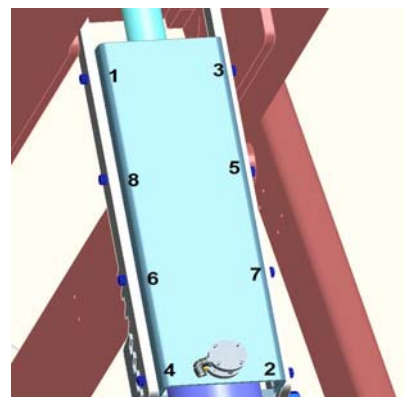

5. Raise the lift and then lower it down, and visually inspect to make sure the adjustment is even. If the adjustment is not even, follow each step again until safety locks touch evenly.

## 13.0 TROUBLE SHOOTING

PROBLEM	REASON	SOLUTION
Motor does no turn.	Bad fuse or circuit breaker.	Re place fuse or reset breaker.
	Incorrect voltage to motor.	Provide proper voltage to motor.
	Incorrect wiring.	Have certified electrician check
	Motor switch is malfunctioning	Replace motor switch.
	Motor burned out	Re place motor.
Motor runs but lift doesn't go up .	L ow oil level	Fill reservoir with proper hydraulic oil.
	Wrong rotation	Check for oil flow & reverse electrical leads
Lift doesn't come down.	Dirt in hydraulic lines	*Secure vehicle on lift, and clean hydraulic lines.
	Check power to hydraulic lines	
	No power to solenoids	Check power to solenoids
Safety doesn't disengage .	Lift not raised high enough for disengagement	Press Up button for longer period of time .
	Air not supplied to air cylinder	Check if supply line has air.
	Air cylinder malfunctioning	Replace air cylinder.
Lift goes up un-level.	Flow-divider defective	Reverse hydraulic connections
	Blockage in hydraulic hose	Remove & inspect flow through line
Anchor Bolts do not stay tight	Holes are to large.	Relocate lift using proper drill Size.
	Incorrect concrete floor specification. (Thickness and Strength)	Concrete should be replaced by an appropriate concrete pad . (Consult Product Manufacturer / Supplier for further details)



## 14.0 RECORD OF MAINTENANCE / TRAINING

Records of all lift maintenance and operator training should be recorded in the following table.

MAINTENANCE & TRAINING PERFORMED	DATE	BY:	NOTES

# 15.0 LIFT ASSEMBLY

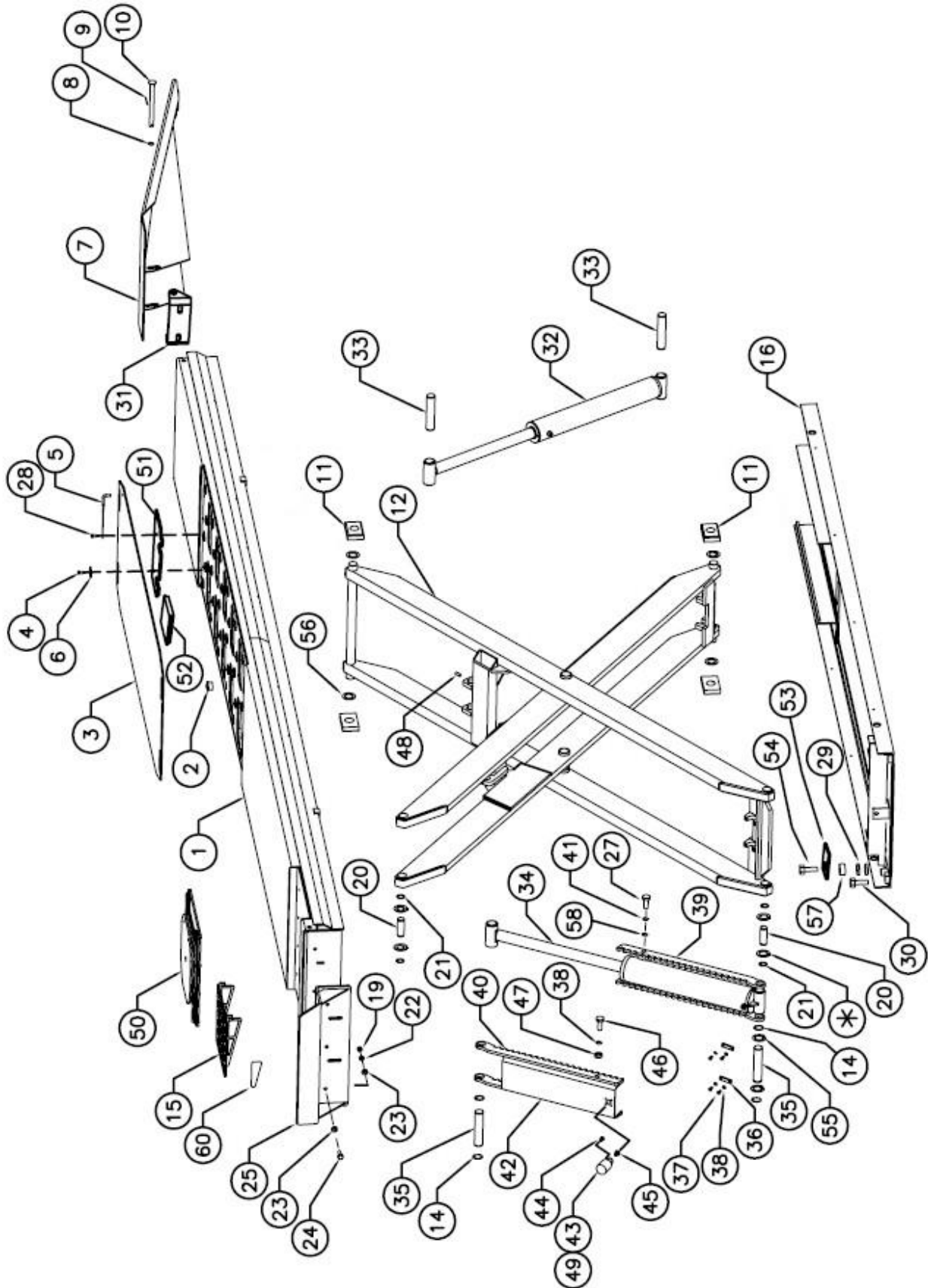

## 15.1 Lift Assembly Parts List

Item #	Part #	Description	Qty.
1	4-1091	Deck Weldment RS	1
	4-1275	Deck Weldment RS (Locking & Lights Option)	1
	4-1090	Deck Weldment LS	1
	4-1276	Deck Weldment LS (Locking & Lights Option)	1
2	6-2940	Ball Bearing	54
3	2-2088	Rear Slip Plate	2
	2-2721	Rear Slip Plate Weldment – LS (Locking & Light Option)	1
	2-2740	Rear Slip Plate Weldment – RS (Locking & Light Option)	1
4	6-0206	Shoulder Bolt 3/8" X 1.0"LG	8
5	2-0637	Locking Pin Assembly	4
6	6-0426	Flat Washer	8
7	3-0905	Approach Ramp Assembly	2
8	6-0738	Washer 3/4" Flat	4
9	6-0267	Cotter Pin, 1/8"Dia. X 1" Long	4
10	1-1887	Approach Ramp Pin	4
11	2-2725	Slider Block	8
12	4-1081	Scissor Weldment	2
14	6-0233	Snap Ring #5100-150	8
15	2-2119	Workstep Weldment	2
16	3-0978	Baseframe Weldment	2
19	6-0035	Hex Nut 1/2"-13UNC, Zinc Plated	12
20	1-2788	Hinge Pin	8
21	6-0340	Snap Ring #5100-125	16
22	6-0059	Lock Washer 1/2"	12
23	6-0063	Flat Washer 1/2"	24
24	6-0291	Hex Bolt 1/2"-NC X 1 1/2" Long	12
25	2-2117	Wheelstop Weldment	2
27	6-2936	Hex Bolt, 3/4"-NF x 1 1/2" LG	4
28	6-0505	Self Tapping Screw, #10 x 1/2" LG	4
29	80259000	Hex Jam Nut, 3/4"-NF	10
30	6-1670	Hex Bolt GR5, 5/8"-NC x 2" LG	10
31	1-3159	Adapter Plate	2
32	3-0897	***Cylinder Assembly, Secondary	2
33	1-2790	Cylinder Pin, Secondary	4
34	3-0896	Cylinder Assembly, Primary	2
35	1-2789	*** Cylinder Pin, Primary	4
36	1-2793	Cylinder Retainer	8
37	6-0067	Hex Bolt, 3/8"-NC x 1" LG	16
38	6-0058	Lock Washer, 3/8"	32
39	2-2111	Safety Bar, Bottom	4
40	2-2112	Safety Bar, Top	4
41	6-0259	Lock Washer, 3/4"	4
42	2-2183	Safety Cover	2
43	3-0812	Air Cylinder Assembly ( * See below for individual parts)	2
44	2-1733	Rod End, Cylinder	2
45	6-2281	Philips Screw, #6-32 x 3/4" LG	8
46	6-0666	Hex Bolt, 3/8"-NC x 1 1/4" LG	16
47	6-0034	Hex Nut, 3/8"-NC	16
48	6-3061	Set Screw, 3/8"-NC x 1" LG	8
49	6-0183	Breather, 1/8" NPT	2

50	4-1101	Stainless Steel Turnplate Assembly (Optional Accessory)	2
51	1-3033	Rear Slider Plate	4
52	1-3032	Slider Plate Insert	16
53	1-3035	Proxy Plate	2
54	6-3569	Hex Bolt GR5 3/4"-16UNF 2 3/4" PTHD	8
55	1-2905	Spacer Safety Locks	8
56	1-3171	Thrust Washer	8
57	1-1623	Spacer	2
58	6-0738	3/4" Flat Washer SAE	4
60	6-3524	Workstep Warning Label	2
*	0-1506	Hinge Spacer Kit – 1/8" & 1/16" (16/PKG)	1

\*\*\*If required the following numbers can be used to order service parts for the Primary( 3-0896) and secondary (3-0897) cylinders

- 01669 Seal Kit Primary

- 01670 Seal Kit Secondary

\* 3-0812 Air Cylinder Assembly

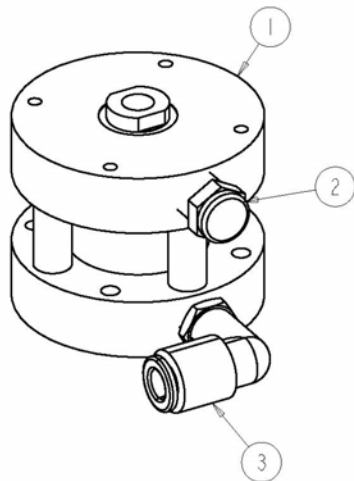

1	6-3722	Air Cylinder	1
2	6-0183	Breather Vent / Exhaust Muffler	1
3	6-0709	90 Deg. Fitting 1/4" Poly – 1/8" NPT	1

# 16.0 HYDRAULIC & AIR ASSEMBLY

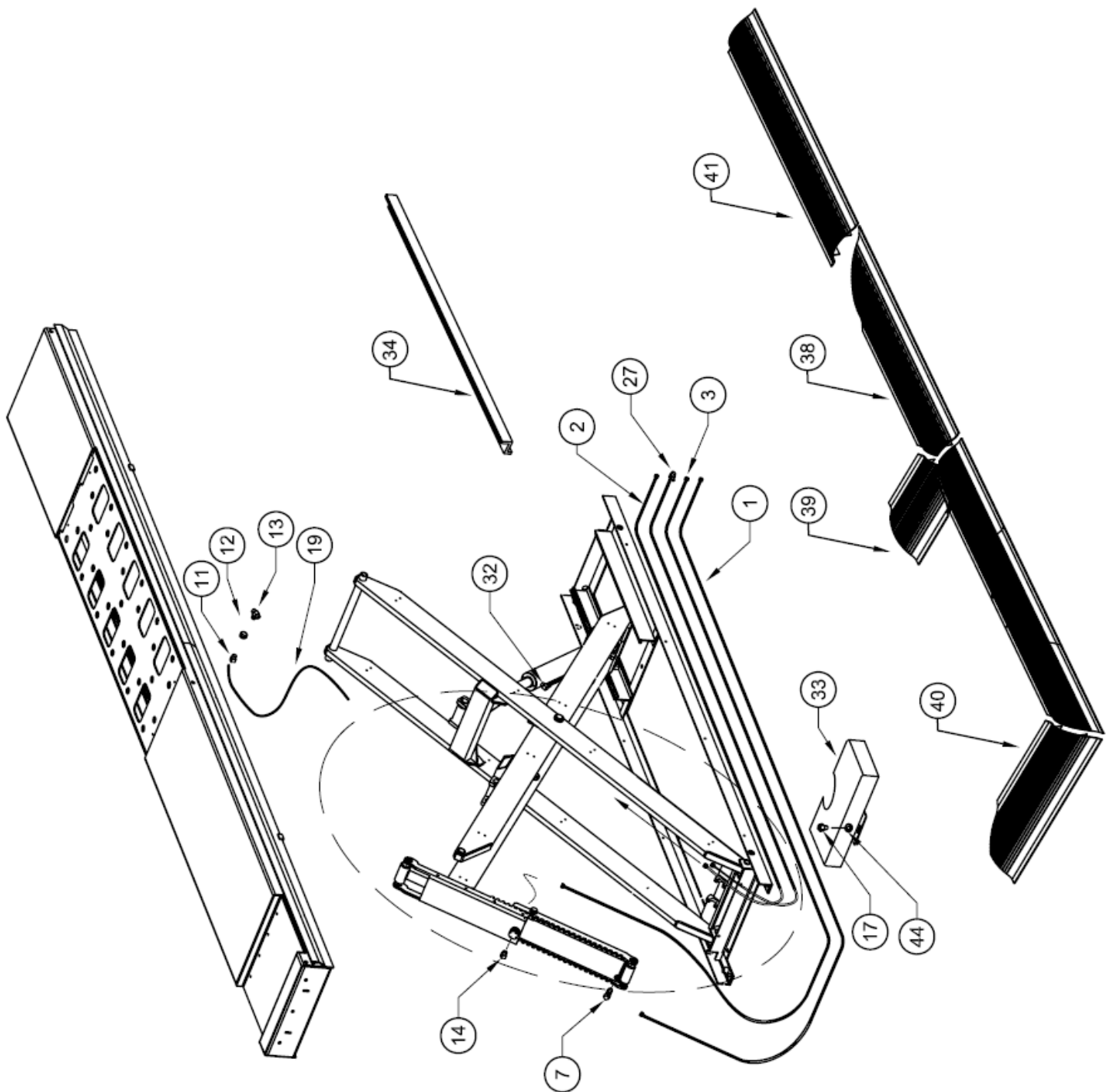

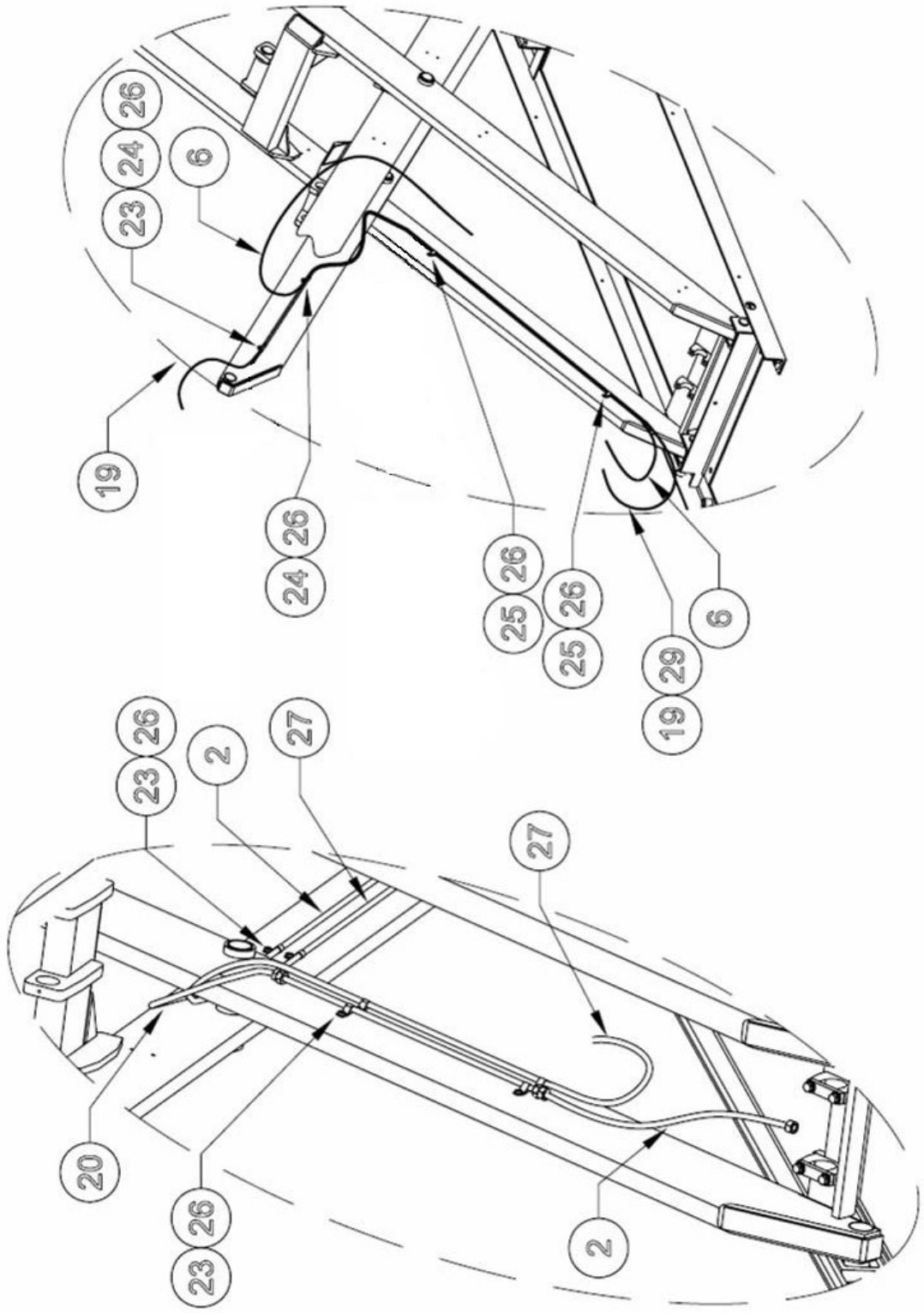

## 16.1 Line Routing Parts List

1	2	3/8" HYDRAULIC HOSE – CYLINDER (LS/RS)	2-2143
2	1	3/8" HYDRAULIC HOSE – LS	2-2718
	1	3/8" HYDRAULIC HOSE – RS	2-2719
3	2	3/8" HYDRAULIC HOSE – EQUALIZE (LS/RS)	2-2717
6	1	1/4" POLYTUBE SAFETY AIR LINE	6-3020
7	2	VELOCITY FUSE	6-2956
10	2	90 DEG ELBOW, 3/8" JIC-M, 3/8' JIC-F	6-0813
11	1	90 DEG ELBOW, 1/4" NPT-M, 3/8" POLYTUBE	6-3010
12	1	TERMINAL BOLT, 3/4"	6-0167
13	1	BRANCH TEE FITTING, 1/4 NPT, F-F-M	6-3896
14	2	90 DEG ELBOW, 1/8" NPT, 1/4" POLYTUBE	6-0709
15	1	TEE FITTING, 1/4" POLYTUBE	6-2971
16	2	FRONT COVER	2-2185
17	6	HEX BOLT, 1/4" NC x 3/4" LG	6-0178
18	2	LOCKWASHER, 1/4"	6-0056
19	1	3/8" POLYTUBE SUPPLY AIRLINE	6-3019
23	6	PIPE CLAMP, 3/8"	6-0170
24	14	PIPE CLAMP, 1/2"	6-0536
25	6	PIPE CLAMP, 5/8"	6-1547
26	24	SELF THREADING SCREW	6-1134
27	2	POLYTUBE RETURN LINE 3/8"	6-3082
32	2	90 DEG ELBOW, 3/8" NPT-M, 3/8" POLYTUBE	6-3058
33	2	FRONT COVER	2-2803
34	2	BASEFRAME LINE COVER LH	2-2299
37	2	HEX SOCKET CAP SCREW #10-24 UNCx 1"LG	6-3096
38	2	FLOOR LINE COVER "B"	2-2734
39	2	FLOOR LINE COVER "C"	2-2735
40	2	FLOOR LINE COVER "A"	2-2733
41	2	FLOOR LINE COVER "D"	2-2736
42	1	BASEFRAME LINE COVER RH	2-2301
44	3	WASHER FLAT 1/4 SAE	6-0060
47	2	NAIL-IN ANCHORS, 1/4" X 1" LG	6-0141

## 17.0 HEIGHT LIMIT ASSEMBLY

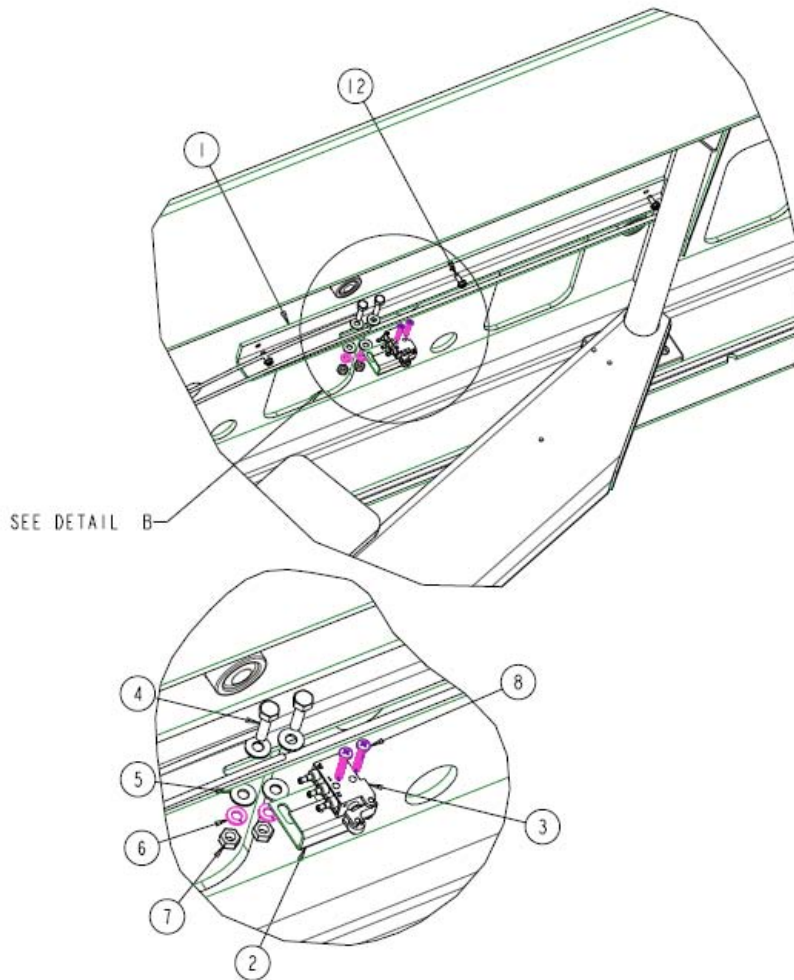

**Note:** Height Limit Sensor is located under Rear of Driver Side Deck.

### 17.1 HEIGHT LIMIT / LEVELING PARTS LIST

Item #	Part #	Description	Qty.
1	1-3770	Sensor Track	1
2	1-3771	Sensor Bracket	1
3	6-3964	Limit Switch w/ Roller Lever	1
4	6-0008	Hex Head bolt, 1/4"-20UNC x 1" Lg.	2
5	6-0060	Flat Washer, 1/4"	4
6	6-0056	Lock Washer, 1/4"	2
7	6-0032	Nut, 1/4"-20UNC	2
8	6-3965	Pan Hd Machine Screw, 8-32 x 1"lg	2
12	6-1134	Threat Cutting Screw, #12 x 1/2"lg	3



## 17.2 EQUALIZE SENSORS PARTS LIST

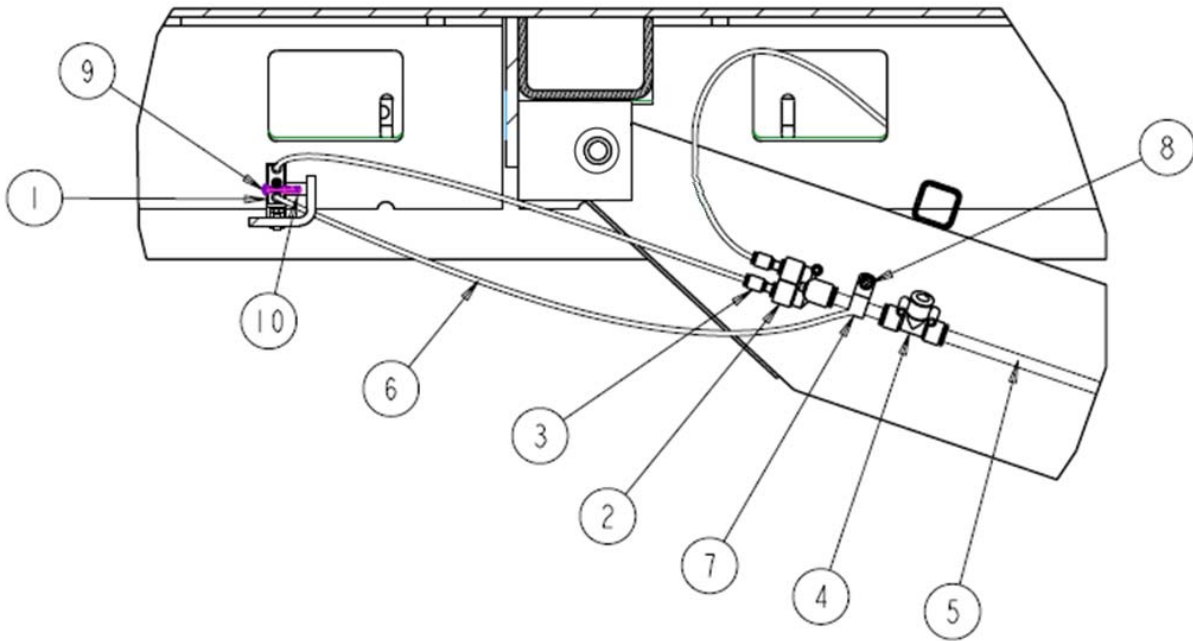

**Note:** Equalizing Sensors are located under Front of Driver & Passenger Side Deck.

## 17.3 HEIGHT LIMIT / LEVELING PARTS LIST

Item #	Part #	Description	Qty.
1	6-3964	Limit Switch w/ Roller Lever	1
2	6-3943	Branch Y, 3/8" – 1/4"	1
3	6-3928	Reducer, 1/4" – 5/32"	2
4	6-3011	Tee fitting, 3/8"	1
5	6-3019	3/8" Polytube Supply Airline	1
6	8-0378	4mm Polytube Blue (ft)	53
	8-0377	4mm Polytube Red (ft)	125
7	6-0536	Clamp, 1/2"	2
8	6-1134	Thread Cutting Screw, #12 x 1/2" Lg.	2
9	6-3984	Machine Screw, #8 x 1-1/2" lg.	2
10	1-3777	Plastic spacer	2

## 17.4 OPTIONAL: LIGHT KIT SENSOR PARTS LIST

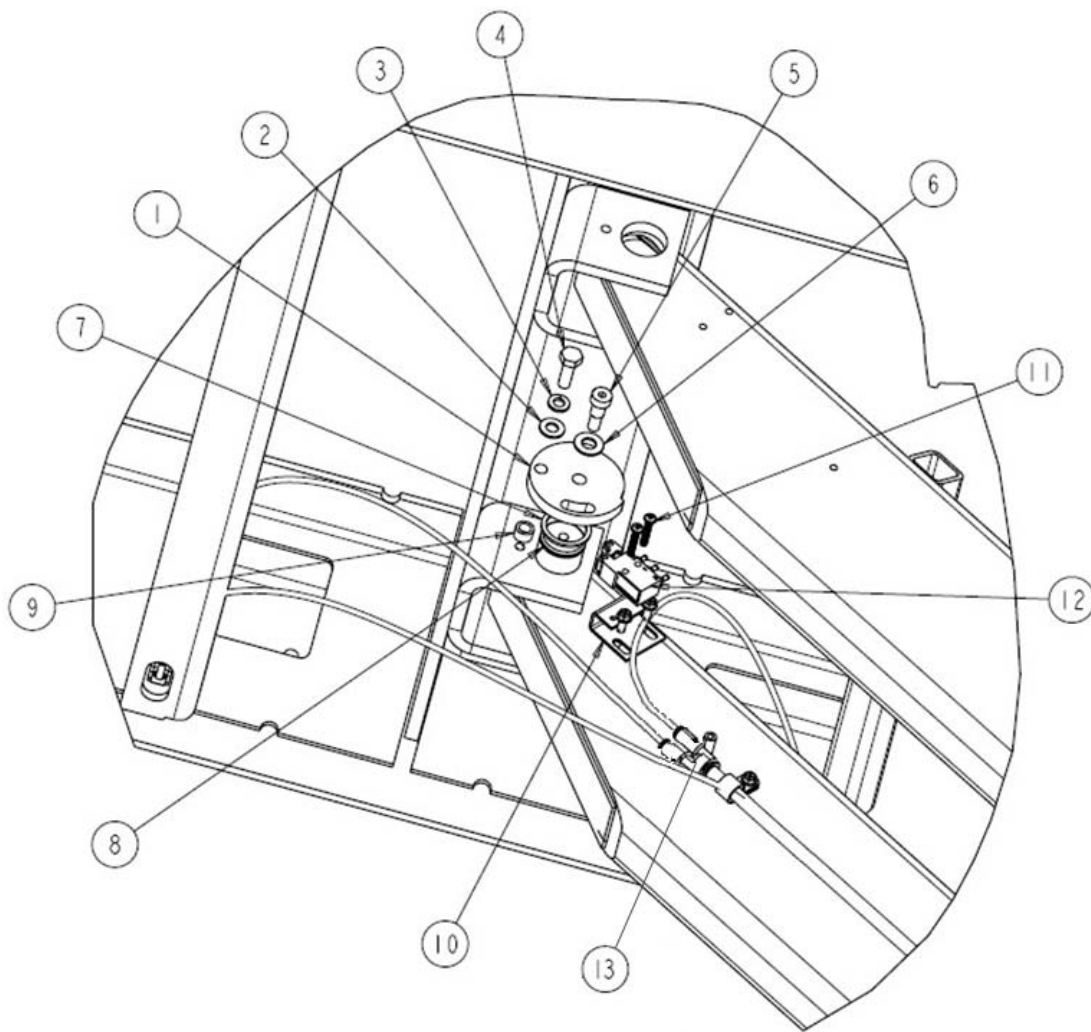

Item #	Part #	Description	Qty.
1	2-2757	Plastic Cam	1
2	6-0295	Flat Washer, 5/16"	1
3	6-0674	Lock Washer, 5/16"	1
4	6-0293	Hex Head bolt, 5/16"-18UNC x 1" Lg.	1
5	6-1792	Shoulder Bolt, 3/8" x 1/2" Lg.	1
6	6-0062	Flat Washer, 3/8"	1
7	6-0340	Circlip	2
8	1-3754	Hinge Pin, Cam	1
9	1-3752	Spacer	1
10	1-3771	Sensor Bracket	1
11	6-3965	Machine screw, #8-32 x 1"lg	2
12	6-3964	Limit Switch w/ Roller Lever	1
13	6-3944	Union, 'Y', 5/32" (4mm) Polytube	1
*	8-0378	4mm Polytube Blue	40 ft
*	8-0377	4mm Polytube Red	40 ft

**Note:** Light Kit Sensor Assembly is located under Passenger Side Deck.

# 18.0 ACCESSORY ASSEMBLY

## 18.1 Front Turnplate

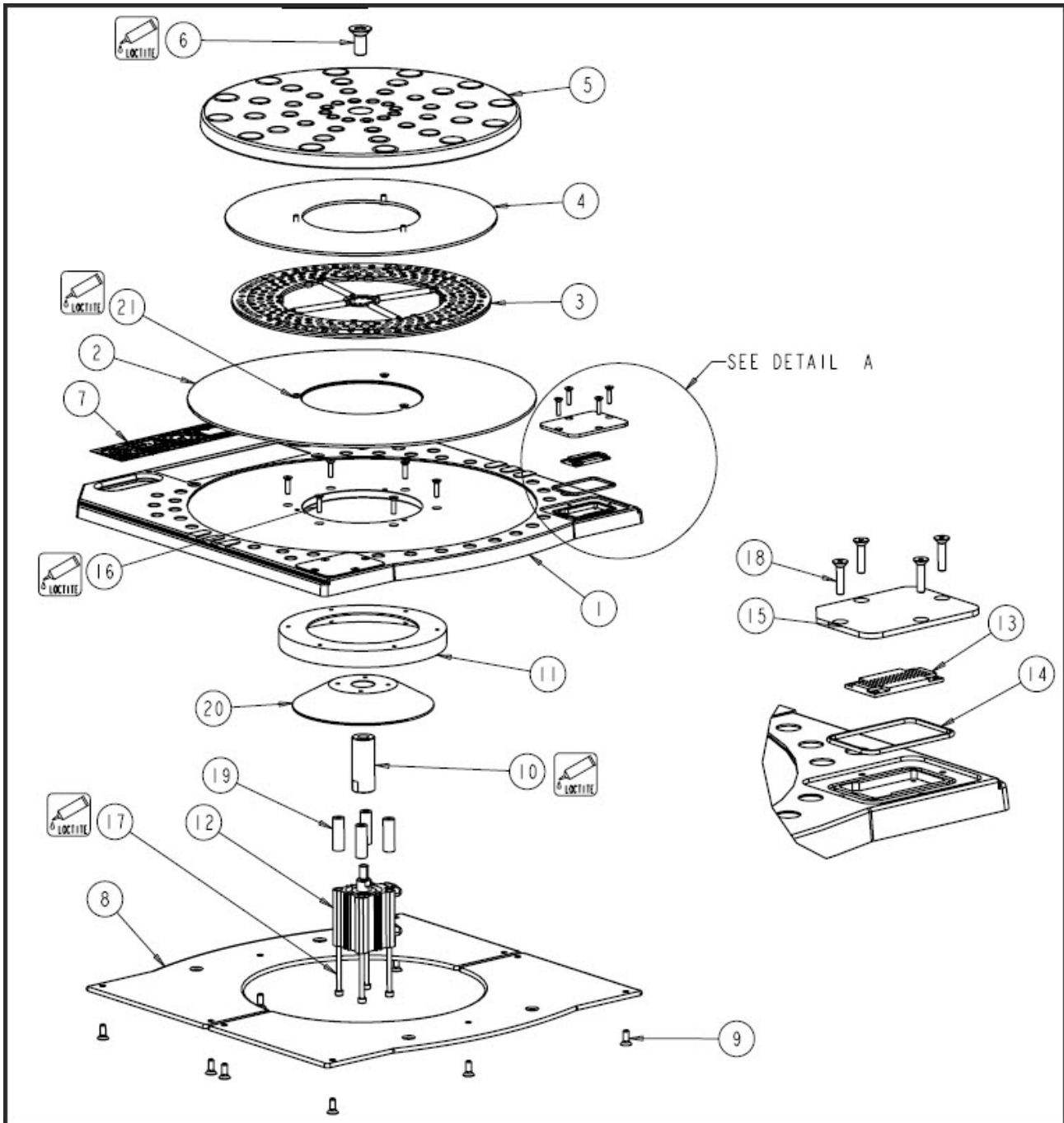

## TURNPLATE ASSEMBLY: PARTS LIST

Item #	Part #	Description	Qty.
1	2-2727	Turnplate Assembly (Complete)	1
2	EAM0047J58A	Bottom Wear Plate	1
4	EAM0047J57A	Wear Plate, Top	1
5	EAM0047J60A	Turnplate Top	1
7	1-3719	Label	1
8	EAM0047J52A	Wear Pad, Bottom	10
10	1-3678	Stub Shaft	1
11	2-2711	Centering Ring	1
12	6-3899	Locking Cylinder Assembly	1
13	6-3912	LED Light Pad	2
14	6-3906	O-Ring Seal	2
15	1-3682	Plastic Lens Cover	2
16	6-3904	FHCS, #10-32 UNF x ¾", SS	6
17	6-3902	SHCS, M5-0.8 x 120mm Lg	4
18	6-3903	FHCS, #8-32 UNC x ¾", SS	8
19	1-3677	Cylinder Stand-off	4
20	2-2709	Centering Cone	1
22	6-3925*	Cable Assembly, LED light (not shown)	1

\* Not shown

*Note: Please contact customer service for items not listed.*

## 18.2 Rear Slip Plate Locking Mechanism

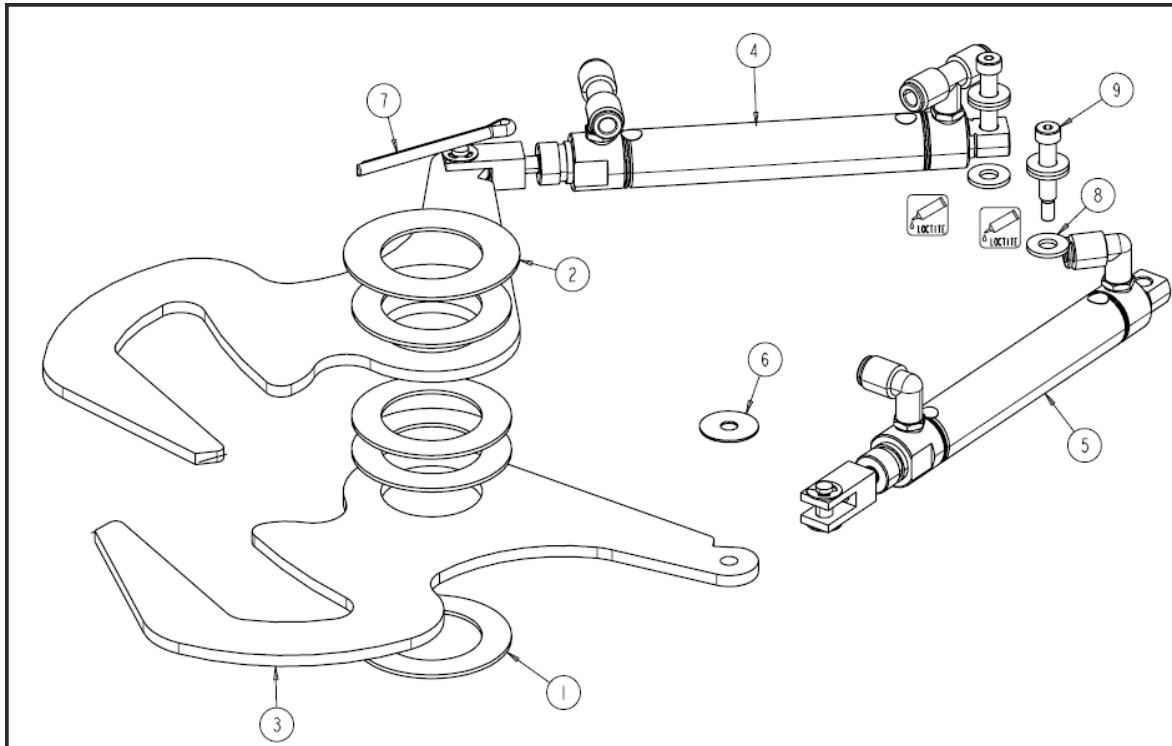

Item #	Part #	Description	Qty.
1	1-0757	Nylon Thrust Washer	4
2	1-3686	Spacer	1
3	2-2712	Retainer Jaw	2
4	6-3900	Cylinder Assembly	1
5	6-3883	Cylinder Assembly	1
6	6-3882	Washer, Nylon 1/4" ID 5/8" OD	2
7	6-3929	Cotter Pin, 3/16" x 2" lg, SS	1
8	6-0060	Flat Washer, 1/4" ID	6
9	6-3907	Shoulder Bolt, 1/4" x 5/8" lg. SS	2

### 18.3 Airline Routing for Locking Turnplates and Rear Slip Plates

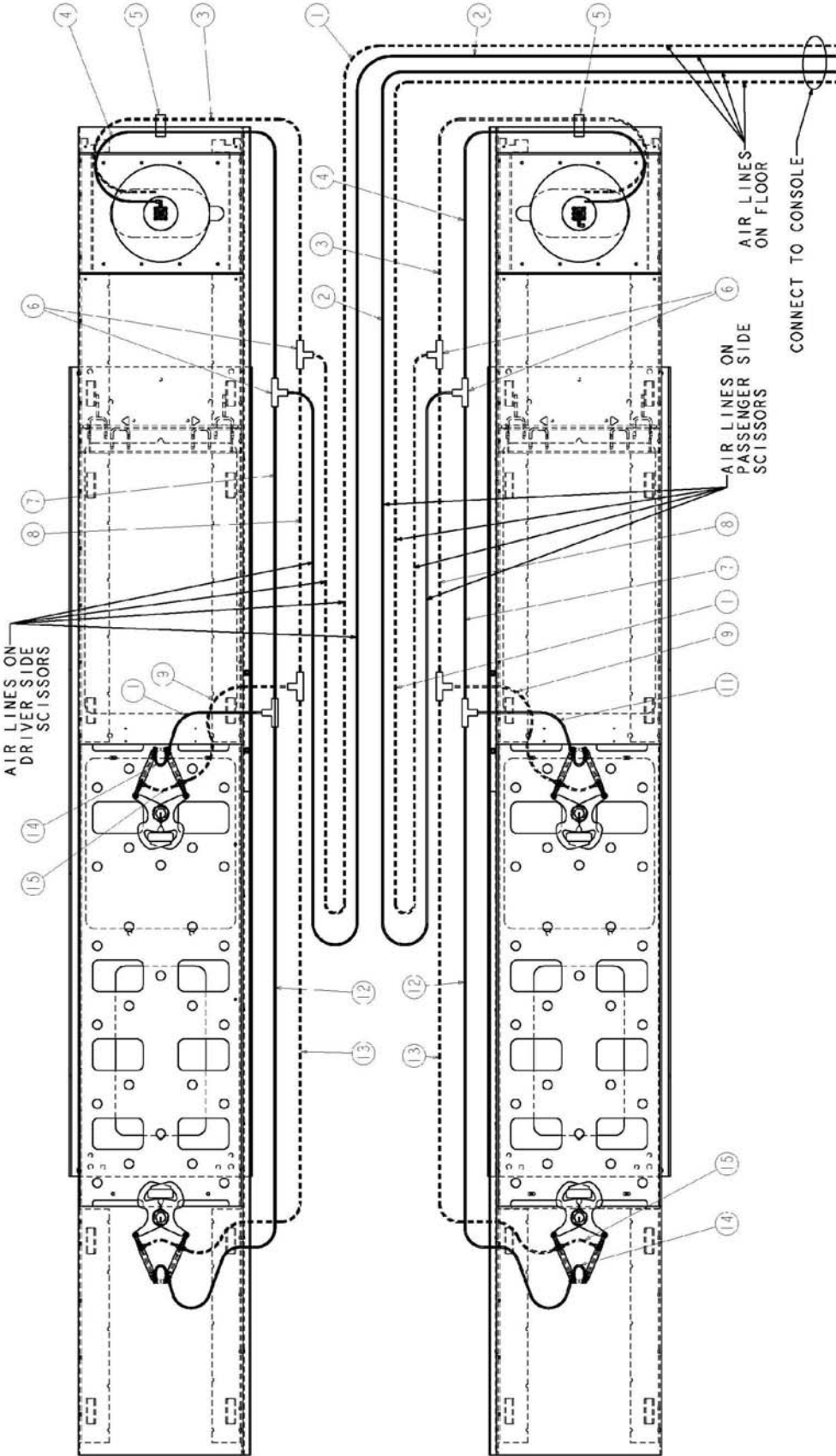

## Airline Parts List

Item	Part Number	Description	Location	Qty/Lift
1	1-3733	Air Line, Blue, 1/4", 45'	From Console, on floor, on scissors, up to deck hinge	2
2	1-3732	Air Line, Red, 1/4", 45'	From Console, on floor, on scissors, up to deck hinge	2
3	1-3735	Air Line, Blue, 1/4", 7.8'	On decks, from hinge to front	2
4	1-3734	Air Line, Red, 1/4", 7.8'	On decks, from hinge to front	2
5	6-3950	Tube Clamp	On decks, at front	2
6	6-2971	Fitting, Tee, 1/4"	On decks / On decks, at middle	8
7	1-3736	Air Line, Red, 1/4", 3.1'	On decks, from hinge to middle	2
8	1-3737	Air Line, Blue, 1/4", 3.1'	On decks, from hinge to middle	2
9	1-3741	Air Line, Blue, 1/4", 1.25'	On decks, feeding middle clamp	2
11	1-3740	Air Line, Red, 1/4", 1.25'	On decks, feeding middle clamp	2
12	1-3738	Air Line, Red, 1/4", 8.25'	On decks, middle to rear	2
13	1-3739	Air Line, Blue, 1/4", 8.25'	On decks, middle to rear	2
14	1-3742	Air Line, Red, 1/4", 5"	Between clamp cylinders, rear and middle	4
15	1-3743	Air Line, Blue, 1/4", 7"	Between clamp cylinders, rear and middle	4
*	6-3940	Adhesive Clamps 9/32"	Front to turnplate	4

### 18.4 Rear LED Light Assembly: Exploded View

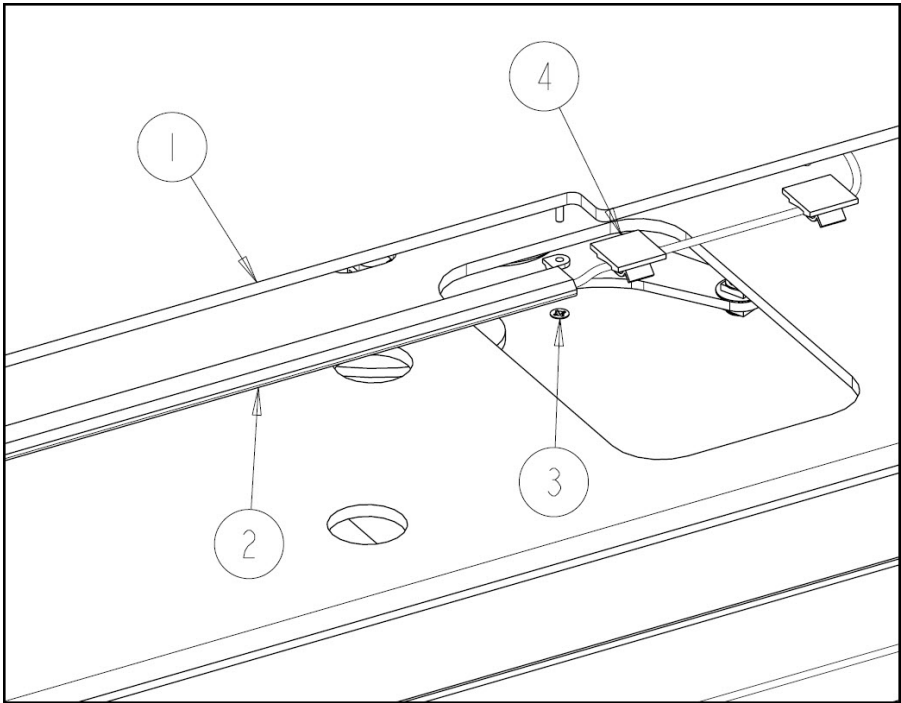

Top of Deck – Rear Slip Plate

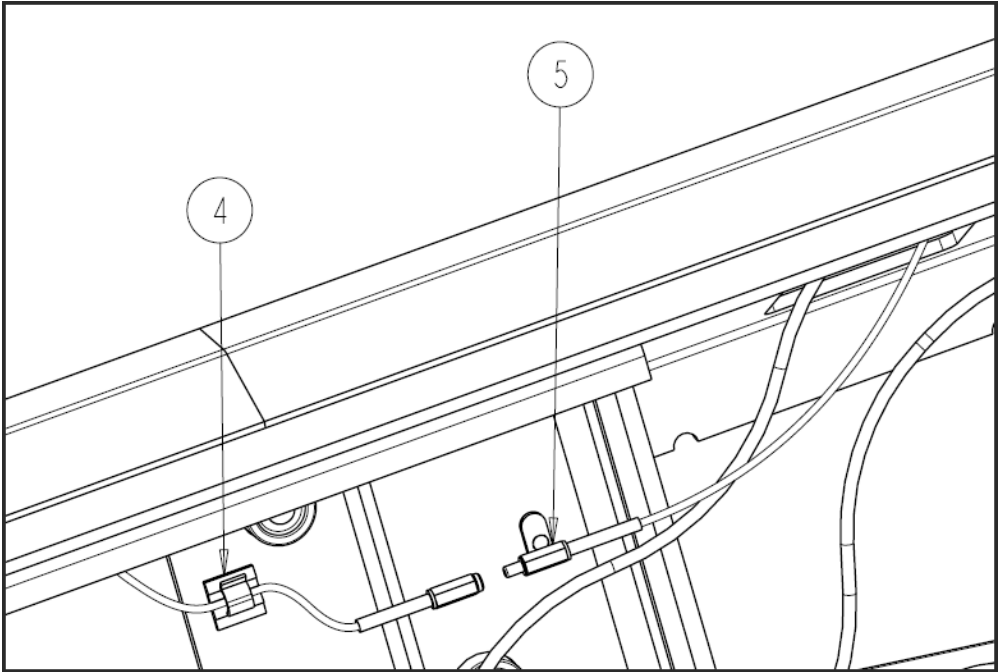

Underside of Deck – Connection of LED Light Bar



## REAR LED LIGHT ASSEMBLY: Parts List

Item #	Part #	Description	Qty.
1	2-2721	Rear Slip Plate Weldment, LS	1
	2-2740	Rear Slip Plate Weldment, RS	1
2	6-3922	LED Light Bar w/ mounts & connector	2
3	6-3936	Push Retainer	4
4	6-3940	Adhesive Back Clamps	8
5	6-3924	Cable Extension Assembly (F&R)	2

### Note:

- Cable Extension Assembly contains Front and Rear cables grouped as an assembly. For single cable replacements, please order part # 6-3949 and specify required color (Red or Blue).

## 19.0 CONSOLE ASSEMBLY

### 19.1 Electrical Panel

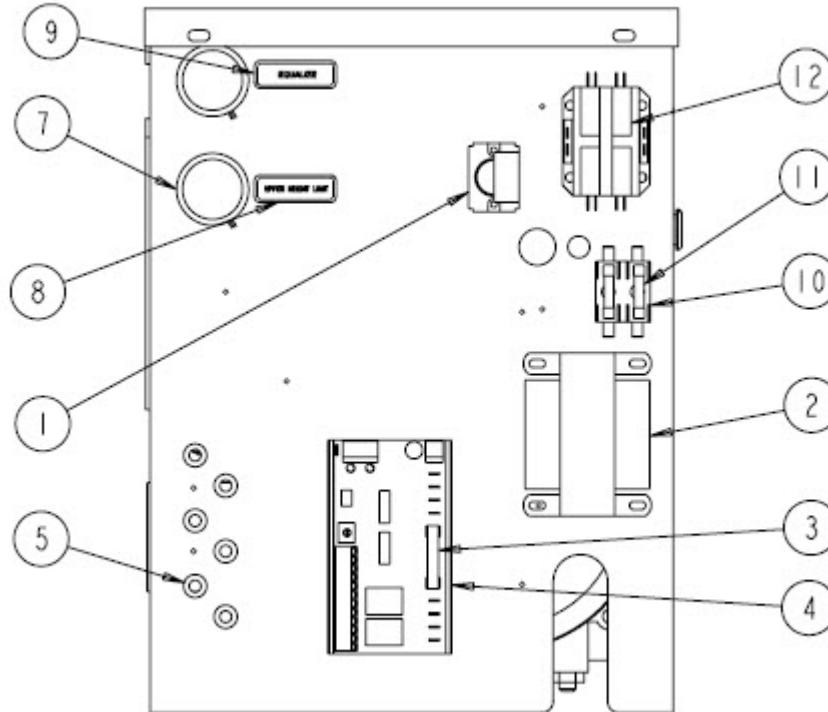

Item #	Part #	Description	Qty.
1	—	Push Button Assembly	1
	6-1247	Push Button	1
	6-1248	Push Button Contact NO	1
2	6-2126	Transformer 230V Primary	1
3	—	Fuse 5A	1
4	6-3280	Circuit Board	1
5	6-3574	Plastic Strain Relief	6
7	6-3941	Pressure Switch w/ Gauge	2
8	6-3067	Decal, "UPPER HEIGHT LIMIT"	1
9	6-3068	Decal, "EQUALIZE"	1
10	6-3595	Fuse Holder – 2 Pole, 20A/250V	1
11	6-3597	Fuse 1A, 250V Time Delay 6x32	2
12	6-3406	Contactor	1

**NOTE: Console Assembly is Part # 3-0901**

**\*\*\*When converting a 1 PH unit to a 3PH unit order all 3PH components marked.**

## 19.2 Console: Pneumatic & Filtering System

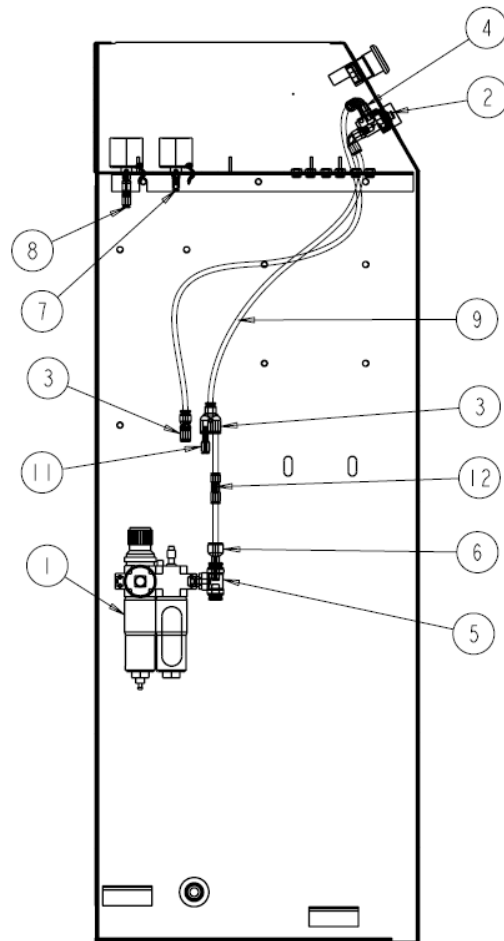
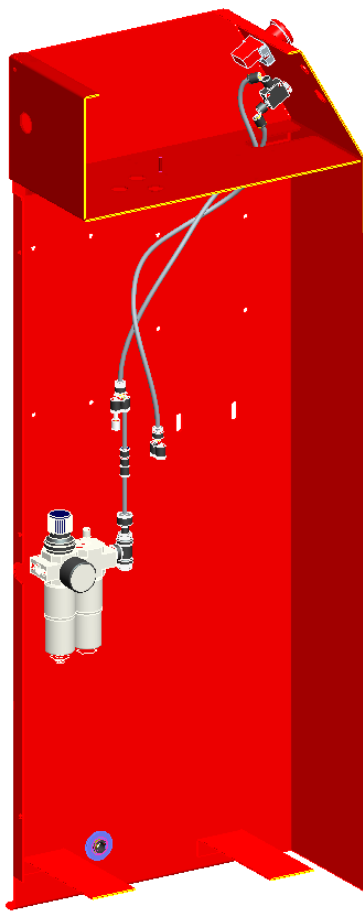

Item #	Part #	Description	Qty.
1	0-1693	Water Separator / Regulator / Lubricator Kit	1
2	6-1055	Control Valve	1
3	6-3729	Union 'Y', 1/4" Polytube	2
4	6-0709	Swivel Elbow, 1/8" NPT x 1/4" Polytube	2
5	6-3730	Swivel 'T' Adapter, 1/4" NPT M x 3/8" Polytube	1
6	6-3731	Reducer, 3/8" Stem x 1/4" Polytube	1
7	6-3942	Union, M5 x 4mm Polytube	2
8	6-3985	Branch 'Y', M5 x 4mm Polytube	1
9	8-0141	1/4" Polytube (ft)	5ft
11	6-3928	Reducer	1
12	6-3952	Check Valve, 1/4 Poly	1

### 19.3 Console: Pneumatic & Filtering System - Locking & Light System (Optional)

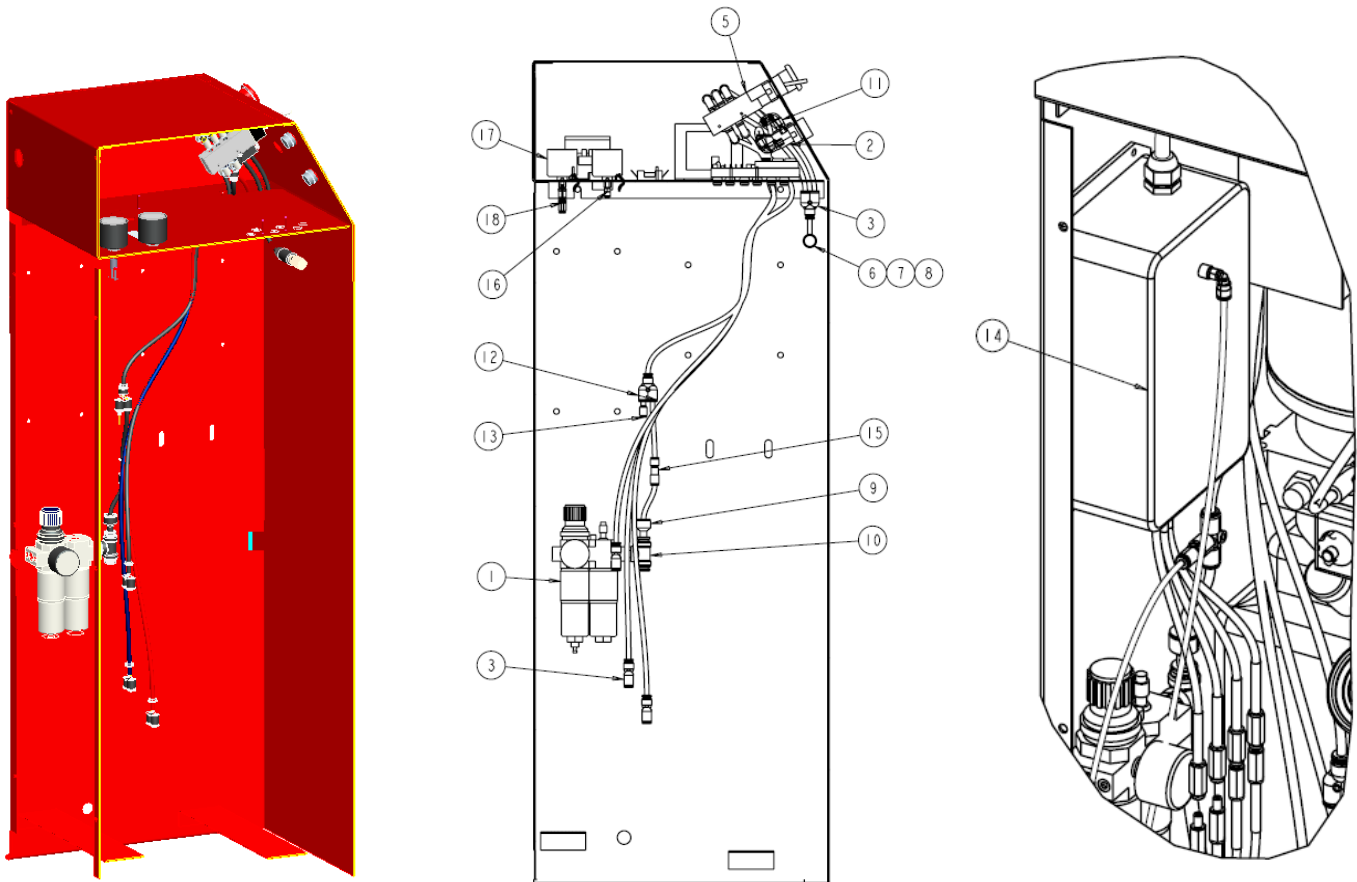

Item #	Part #	Description	Qty.
1	6-3680	Water Separator/Regulator/Lubricator Ass'y	1
2	6-1055	Control Valve (Safety Release)	1
3	6-3729	Union 'Y', 1/4" Poly	5
5	6-3919	Valve Assembly (Locking Plates)	1
6	6-1347	Adapter, 1/4" NPT - 1/4" Poly	1
7	6-0215	Coupler, 1/4" NPT	1
8	6-3930	Muffler	1
9	6-3731	Reducer, 3/8" Stem x 1/4" Poly	1
10	6-3730	Swivel Tee Adapter, 1/4"NPT x 3/8" Poly	1
11	6-0709	Swivel Elbow, 1/8" NPT M x 1/4" Poly	2
12	6-2971	Pushlock Tee, 1/4" Poly	1
13	6-3928	Reducer, 1/4" Stem x 5/32" (4mm) Poly	1
14	6-3923	LED Driver Box Assembly	1
15	6-3952	Check Valve, 1/4" Poly	1
16	6-3942	Union, M5 X 4mm Polytube	2
17	6-3941	Pressure Switch w/ Gauge	2
18	6-3985	Branch 'Y', M5 x 4mm Polytube	1

# 19.4 PNEUMATIC LIMIT SWITCH SCHEMATIC

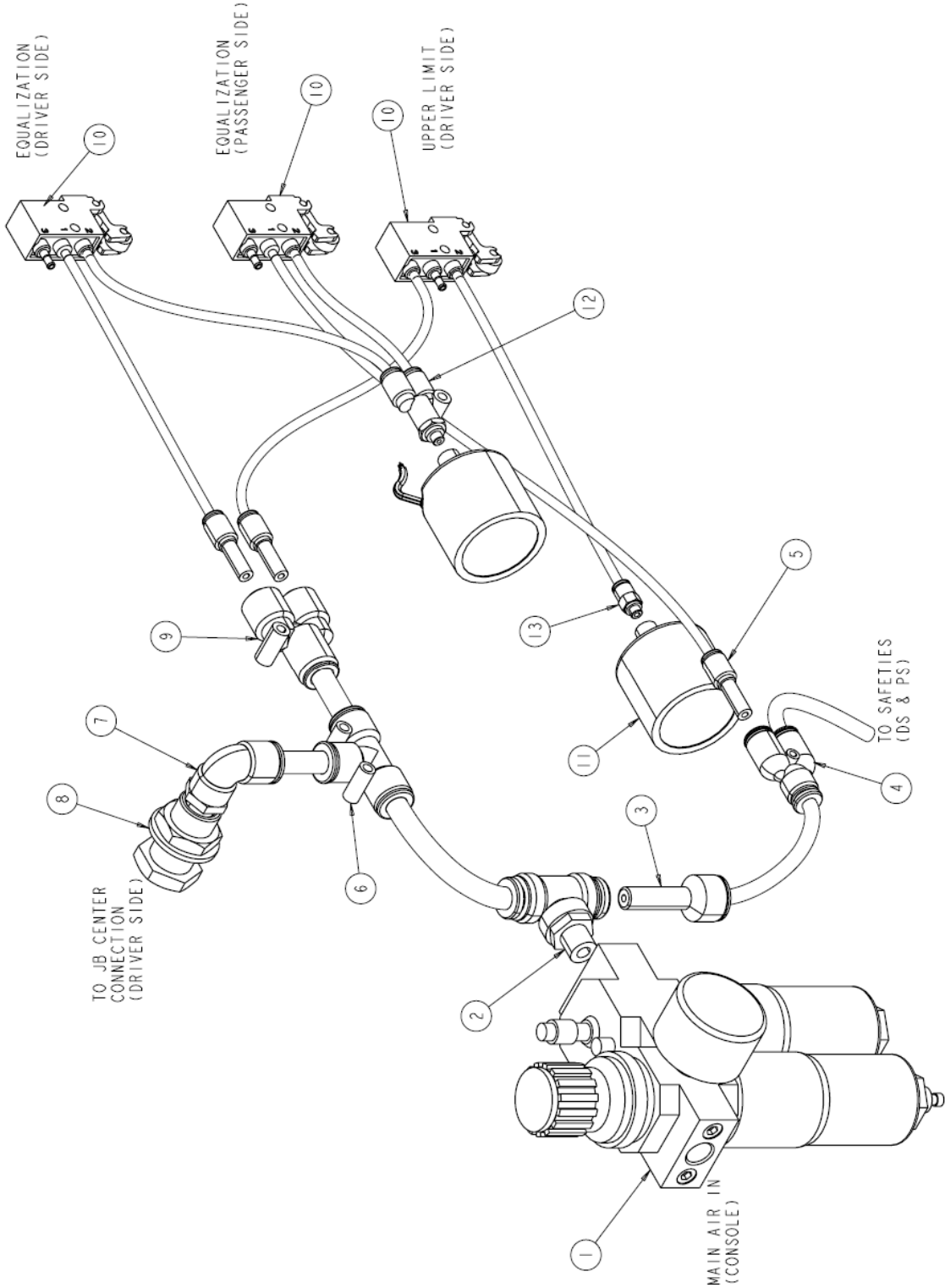

<b>Item #</b>	<b>Part #</b>	<b>Description</b>	<b>Qty.</b>
1	6-3680	Water Separator / Regulator / Lubricator Kit	1
2	6-3730	Swivel 'T' Adapter, 1/4" NPT M x 3/8" Polytube	1
3	6-3731	Reducer, 3/8" Stem x 1/4" Polytube	1
4	6-3729	Union 'Y', 1/4" Polytube	1
5	6-3928	Reducer	3
6	6-3011	Union T, 3/8" Polytube	1
7	6-3010	90 Deg. Elbow, 1/4" NPT-M – 3/8" Polytube	1
8	6-0167	Terminal Bolt, 3/4"	1
9	6-3943	Branch Y, 3/8" Polytube – 1/4" Polytube	1
10	6-3964	Limit Switch, Roller Lever	3
11	6-3941	Pressure Switch	2
12	6-3985	Branch Y, M5 x 4mm Polytube	1
13	6-3942	Union, M5 x 4mm Polytube	1

## 19.5 Control Panel



Item #	Part #	Description	Qty.
1	—	Push Button Assembly	2
	6-1247	Push Button - Arrow	1
	6-1248	Push Button Contact NO	1
2	6-2314	Plastic Plug	1
3	—	Air Valve Assembly	1
	6-1055	Air Safety Release Valve	1
	6-0709	90° Elbow	1
	6-0708	¼" Polytube x 1/8" M NPT Adapter	1
4	—	Emergency Stop Button Assembly	1
	6-2921	Emergency Stop Push Button	1
	6-2922	Emergency Stop Contact NC	1
5	6-3558	Safety Release Decal	1
6	6-3557	Emergency Stop Decal	1
7	6-3623	Duty Cycle Decal	1
<b>* Optional: Locking Turnplates &amp; Slip Plates</b>			
8	6-3919	Valve Assembly	1
9	6-3910	Lock / Unlock Decal	1

## 19.6 Console Panel Assembly

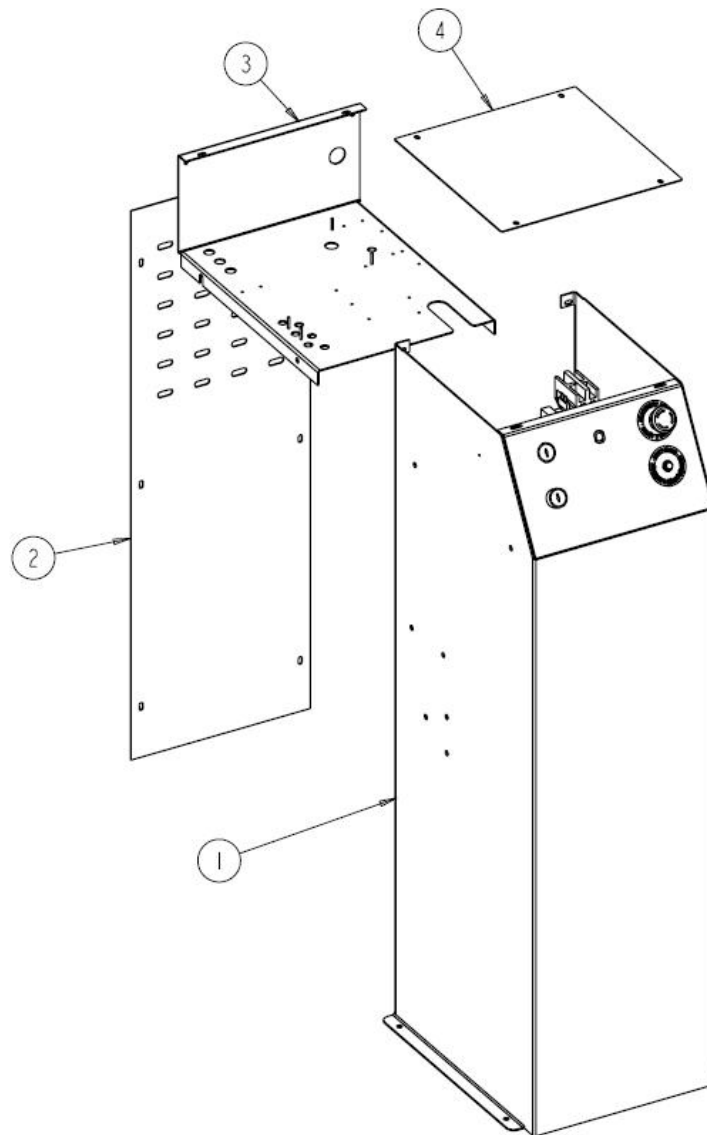

Item#	Part#	Description	Qty.
1	3-0973	Console Front/Side Panel	1
2	2-2512	Console Rear Panel	1
3	3-0974	Electrical Panel	1
4	2-2513	Top Cover	1
includes	6-0141	Concrete Nail 1/4" x 1" Lg.	4
	6-3075	Screw #10-24 x 5/8"	12
	6-3074	U-Type Fastener	12
	6-0816	Flat Washer, #10	12

\* Note: may not be exactly as shown.



# 20.0 POWERPACK ASSEMBLY

## 20.1 Powerpack Assembly

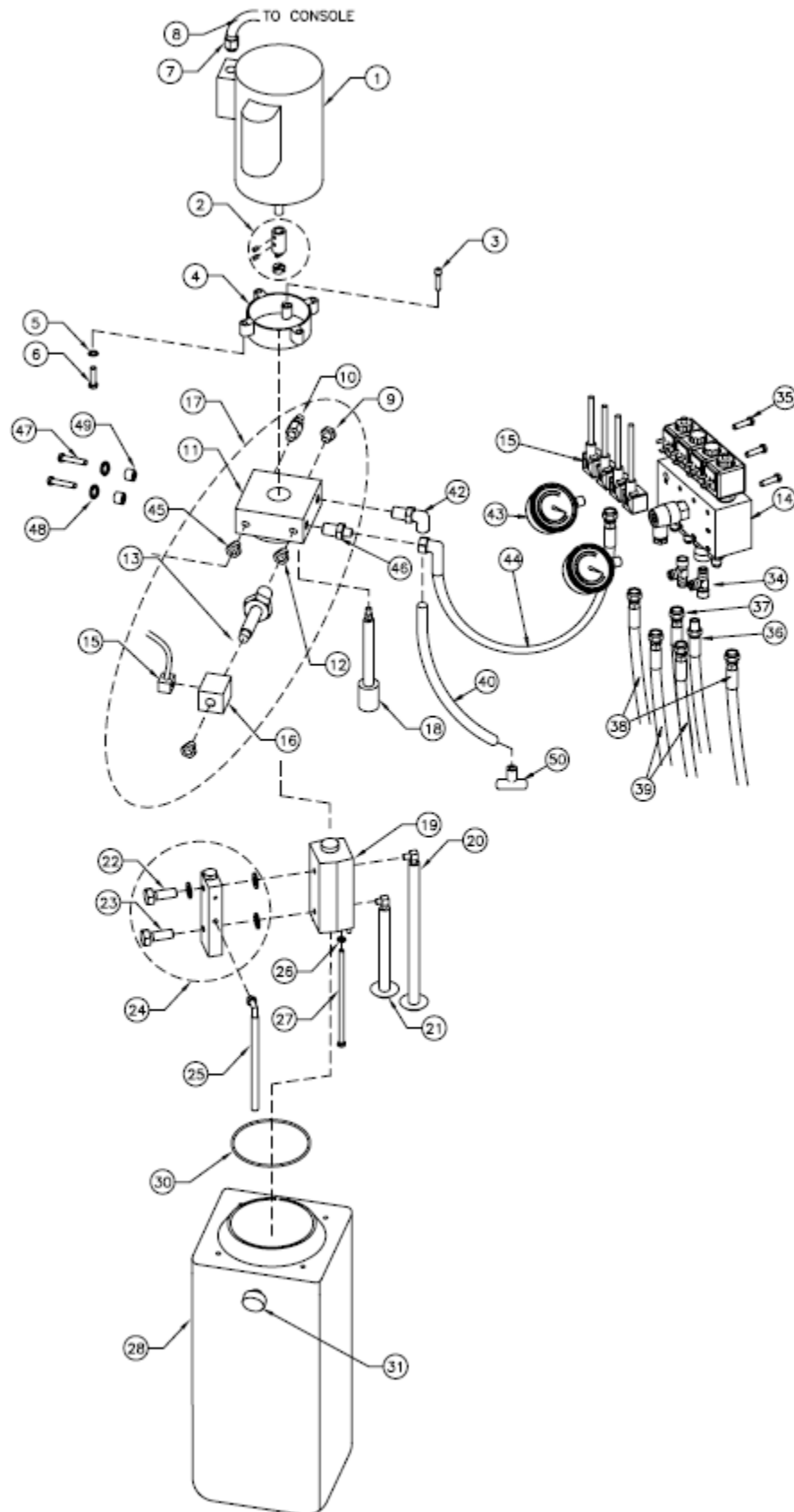

Item #	Part #	Description	Qty.
1	6-0087	Motor, 220V (1 Phase)	1
	6-0446	Motor, 220V (3 Phase)	1
	6-0447	Motor, 575V (3 Phase)	1
2	6-2537	Motor Coupler	1
3	6-2984	Cap Screw, M6x20	2
4	6-2507	Bellhousing	1
5	6-2547	Lock Washer, Internal Tooth, 3/8"	4
6	6-2558	Cap Screw, Hex HD, 3/8"-16UNC x 1 1/2" LG	4
7	6-1370	1/2" Strain Relief Connector (1 Phase)	1
	6-0094	1/2" Strain Relief Connector (3 Phase)	1
9	6-2985	Check Valve	1
10	6-2986	Relief Valve (4500 PSI)	1
11	6-2987	Main Body	1
12	6-2988	Flow Control	1
13	6-2129	Spool Valve (c/w Manual Override)	1
14	6-3877**	Manifold Assembly	1
		<b>**See Next Page for Manifold Assembly</b>	
15	1-3625	DIN Connector (24V) Assembly	5
16	6-2128	Square Coil (24V)	1
17	6-2989	Mainbody Assembly	1
18	6-2990	Return Filter Assembly	1
19	6-2991	Tandem Pump	1
20	6-3631	Long Inlet Strainer Assembly	1
21	6-3632	Short Inlet Strainer Assembly	1
22	6-2525	Banjo Bolt (Includes 2 Washer Seals)	1
23	6-2526	Banjo Bolt (Includes 2 "O"-Rings and 1 Washer Seal)	1
24	6-2555	Unloading Manifold Assembly	1
25	6-3633	Return Tube Assembly	1
26	6-0674	Lock Washer, 5/16"	4
27	6-2533	Cap Screw, Hex HD, 5/16"-18UNC x 6 1/2" LG	2
28	6-3638	Oil Tank 15L	1
30	6-2996	Oil Tank O-Ring	1
31	6-3223	Filler / Breather Cap	1
34	6-0284	Tee Fitting 3/8" JIC, F-M-M	2
35	6-3889	BHSCS, 1/4"-20UNC X 1/2" LG	3
36	2-2719	Hydraulic Hose	1
37	2-2718	Hydraulic Hose	1
38	2-2143	Primary Hydraulic Hose	2
39	2-2717	Equalizing Hydraulic Hose	2
40	6-3082	3/8" Polytube Return Lines	2
42	6-3058	90 Deg Elbow 3/8" NPT to 3/8" Polytube	1
43	6-3474	Hydraulic Gauge, 0-5000 PSI	2
44	2-2592	Hydraulic Hose Assembly	1
45	6-3890	Plug (Oil Fill)	1
46	6-3894	Pressure Fitting w/ Bonded Seal	1
47	6-3563	Button Head Screw M10 X 45MM	2
48	6-0215	Spacer	2
49	6-3892	Lock Washer, M10	2
50	6-3011	Pushlock Tee Fitting, 3/8" Poly	1
<b>*NOTE</b>	<b>6-3881</b>	<b>Pump Assembly</b>	

## 20.2 Manifold Parts List

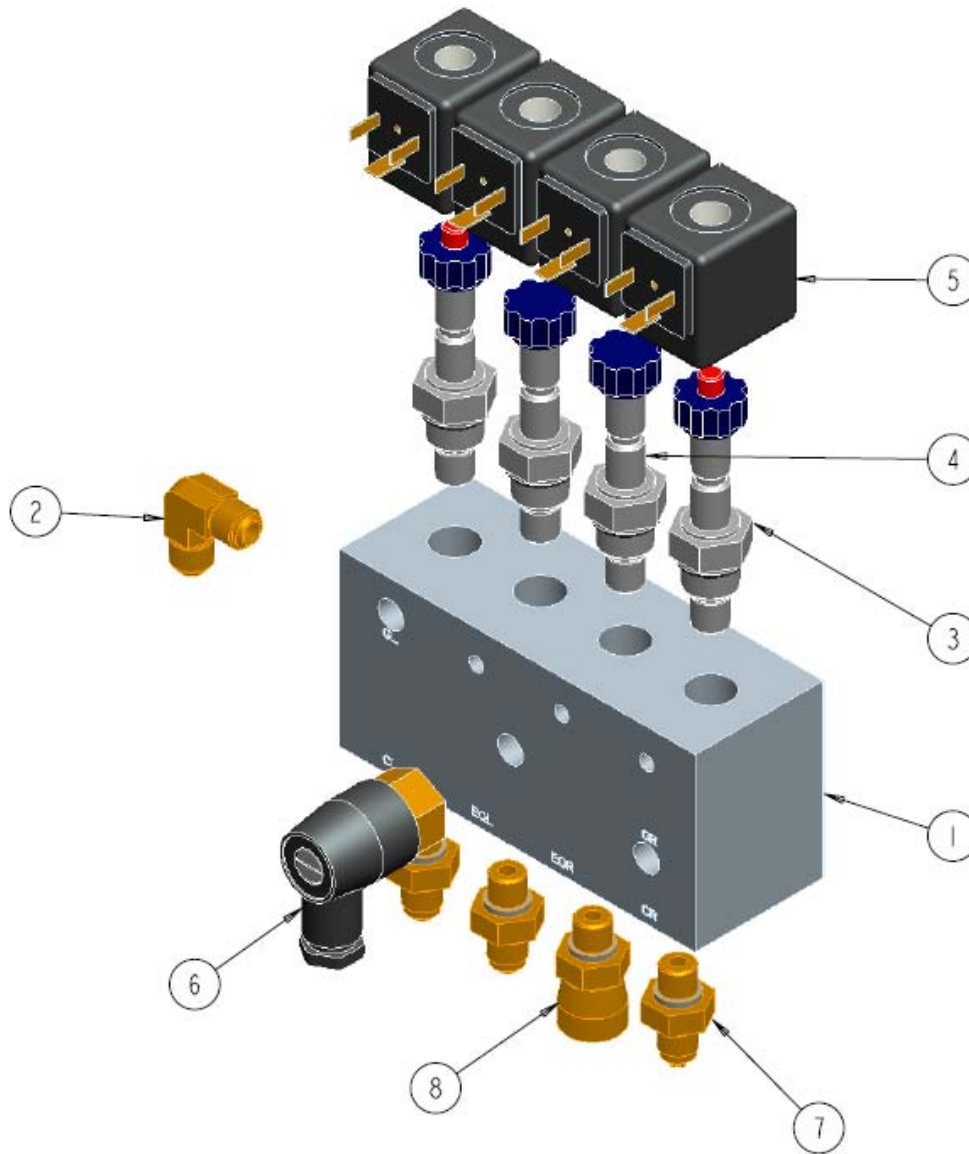

Item#	Part#	Description	Qty.
1	6-3885	Manifold Block	1
2	6-3891	Adapter, Elbow SAE #6 M – 3/8" JIC M	1
3	6-2129	Manual Cartridge Valve	2
4	6-3403	Cartridge Valve	2
5	6-2128	Square Coil 24V	4
6	6-2548	Pressure Switch (Includes Bonded Seal)	1
7	6-3001	Adapter SAE #6 M – 3/8" JIC M	3
8	6-3888	Adapter SAE #6 M – 3/8" JIC F	1

**Note: Complete Assembly Part # 6-3877**